

 Made in Poland. Established 1990.



**POL-EKO**  
Perfect Environment

# CATALOGUE PRODUCTS 2023



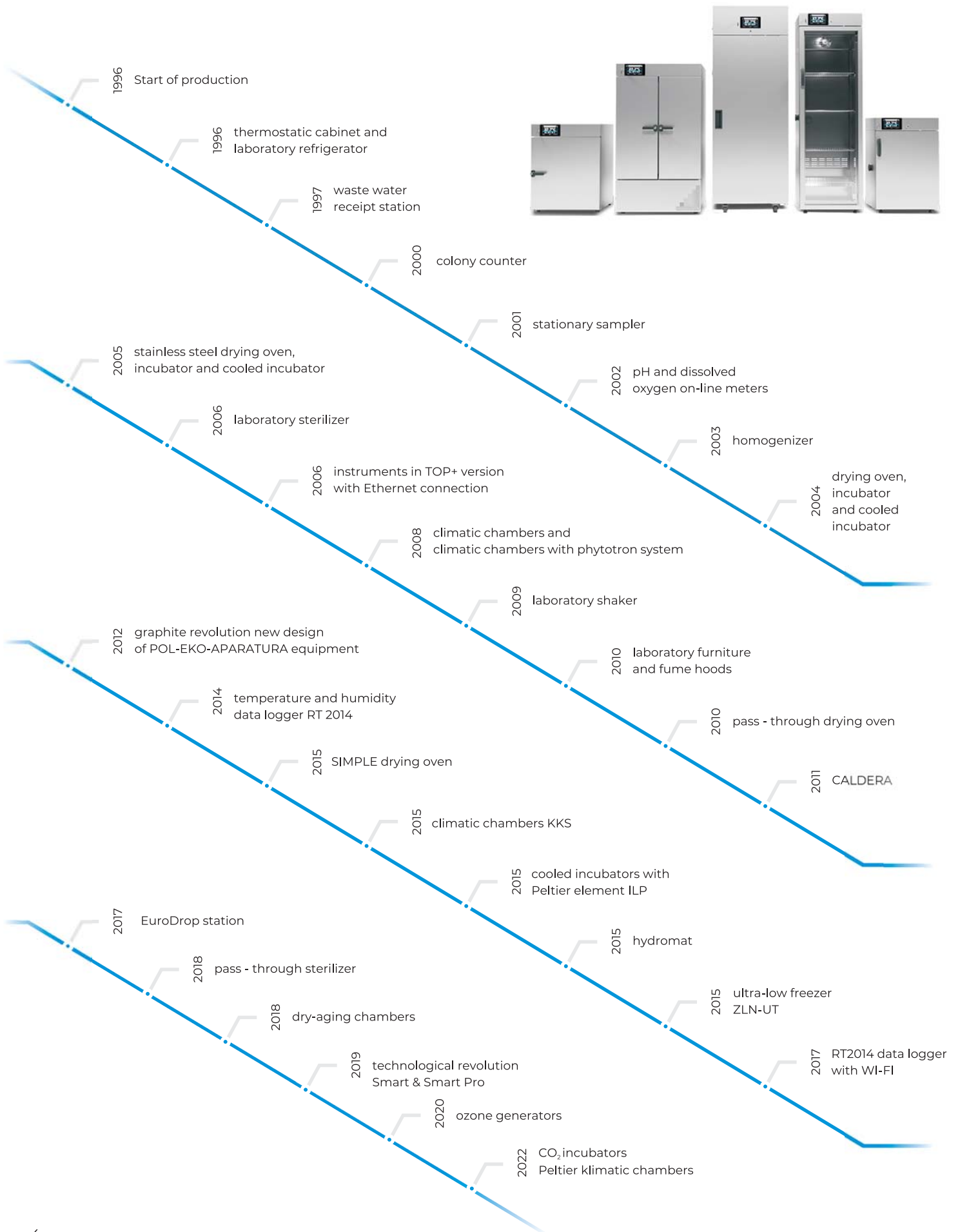

## SRW sterilizers for disinfection of face masks

As the biggest Polish manufacturer of laboratory equipment, we would like to present our hot-air sterilizers which can be used for mask decontamination. Special racks for optimal space use available.

SRW sterilizers for disinfection of face masks (see page 58)

## Ozone generators

They can be used for air decontamination and refreshment. Ozone can neutralize various microorganisms in our surroundings as it has antifungal, antibacterial and antiviral properties. It also deals with odor, completely neutralizing it.



GO24



GO48



GO CAR

GO24/48 ozone generator basic feature

- Environmental conditions: **for indoor use**
- **Start delay** feature
- Maximum continuous operating time: **90 min**
- Minimum rest period after 90min cycle: **20 min**
- Maximum cubic capacity of sterilized areas: **165/420 m<sup>3</sup>**
- Maximum cubic capacity of the sanitized room: **330/840 m<sup>3</sup>**

**Available ozone generators for car disinfection.**

## Manual and automatic dispensers, stainless steel or powder coated sheet

**Touch-free dispensers** with proximity sensors, foot pedal or manual

Available versions

- automatic for AC power supply and a 5L bottle
- manual with a foot pedal and a 5L bottle
- hand-operated for wall or stand installation
  - with a basket for a 1l bottle
  - with a basket for a 0,5l bottle
  - bottle thread-mount for a 1l bottle
  - bottle thread-mount for a 0,5l bottle







# INNOVATIVE CONTROLLERS AND MODEL CHARACTERISTICS



## Smart PRO

Smart PRO controllers are direct followers to the TOP+ controllers and will be available for the KK climatic chambers, IL cooled incubators, SL drying ovens, CL laboratory incubators, as well as the ST cooled incubators, CHL laboratory refrigerators, ZL laboratory freezers and ZLN-UT ultra-low freezers. Smart PRO has a microprocessor-based PID temperature controller with a large (7") colour touch panel and intuitive and user-friendly software.

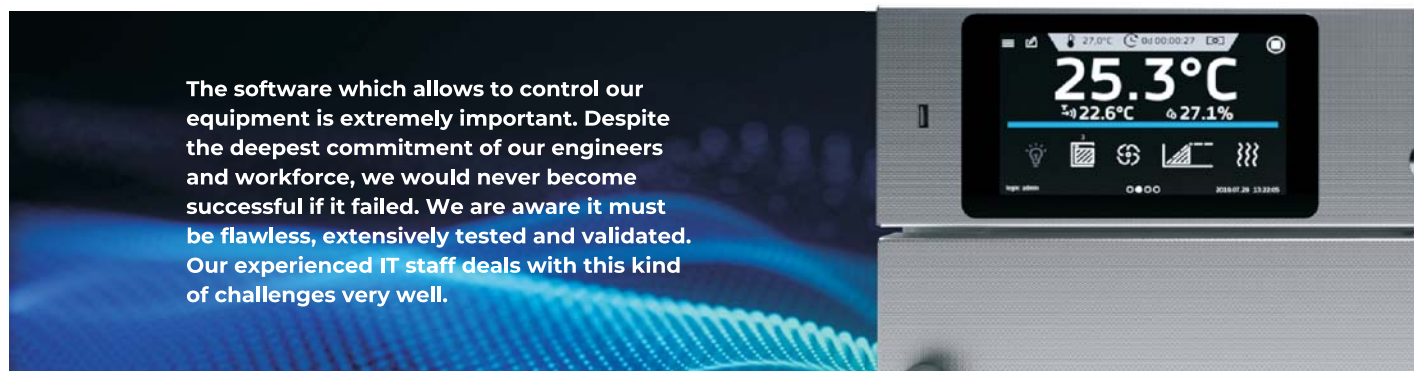

## Getting started

During the first boot, the Smart PRO controller will automatically ask if you want to save the "Download" folder (instruction manual and additional LabDesk software) on the USB flash drive.



## Types of accounts and their limits

Smart PRO controllers have several types of user accounts.

Super Admin - this account has not limits. It has access to the program management menu and to all settings.

Admin - it has access to program management menu, where you can create or edit programs, check their statistics, check the event history and information about the system.

User – it has access to programs shared to him by other users and run them, check statistics, event history and system information. The user cannot create his own programs/schedules and stop those he did not start himself. The program started by the user can be stopped by the Super Admin.

■ 7" colour touch panel Smart PRO guarantees intuitive and comfortable operation

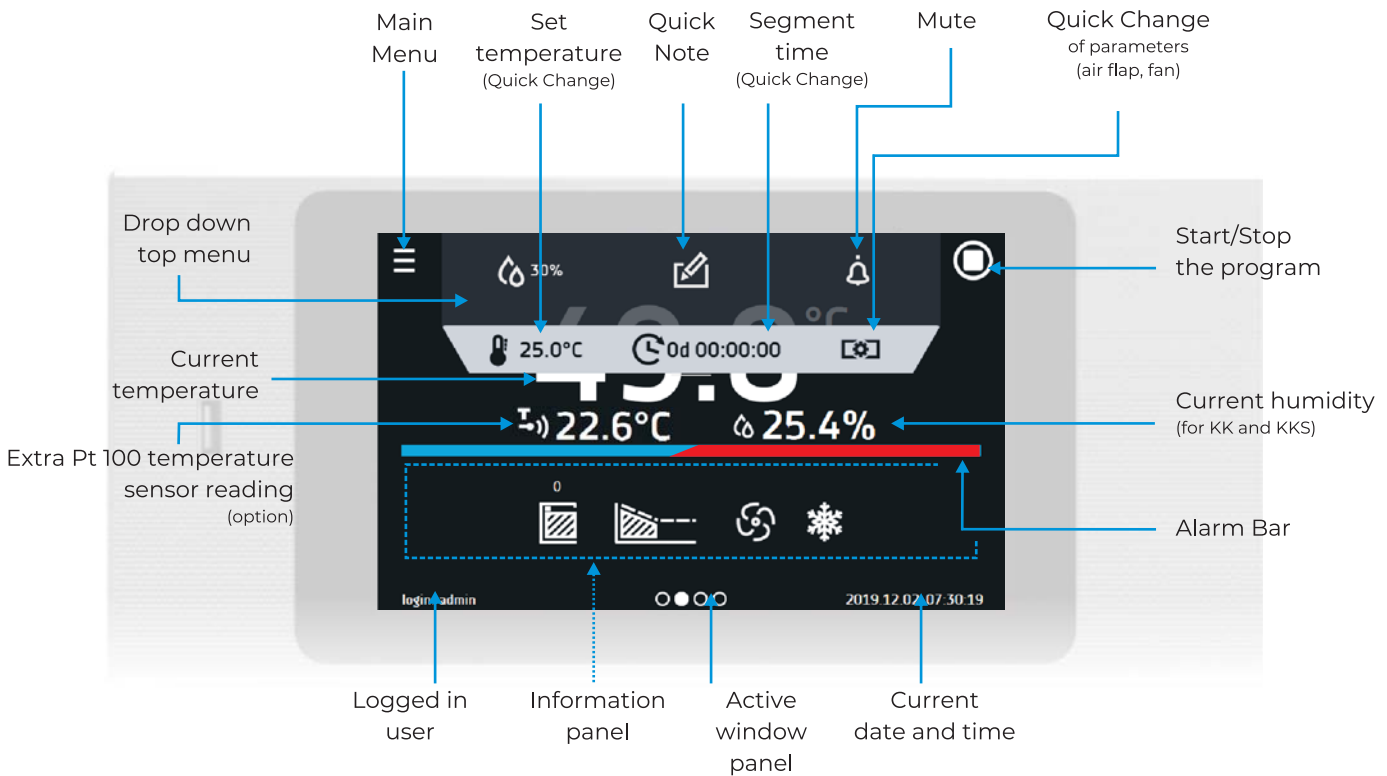

■ Advantages of the Smart PRO controller

- large (7"), clear, full colour touch screen
- LAN, USB ports and WiFi for communication and data transfer
- multi-segment time and temperature programs
- overview of data in tabular and graphic form
- visual and audible alarm
- administration functions for easy management
- password protected log-in
- internal memory for programs and data storage
- operating with gloves on
- event registry with user notifications
- LabDesk software and instruction manual for direct download
- Alarm Bar – instant visual information about chamber status
- Quick Note – user can save text notes (50 characters) in Smart PRO controller memory
- Quick Change of parameters: temperature, humidity, time, air flap and fan (according to model)



Touch screens of the Smart and Smart PRO controllers can be operated with latex gloves!

## Quick Note - GLP supporting feature

Quick Note - while operating the equipment, the user can save messages in the memory, for example, about inserting a new sample or about any changes etc. To enter the message the user must be logged-in. The entered notes can be seen in the event log, they are symbolized by a green envelope icon.



date	name	code
2018.11.14 09:40	User Message	3.01.0.1.001
2018.11.14 09:36	Program deleted	2.01.0.1.023
2018.11.14 09:35	Program Stop	2.01.0.1.008
2018.11.14 09:34	Program Start	2.01.0.1.007
2018.11.14 09:21	User added	2.01.0.1.019
2018.11.14 09:21	User added	2.01.0.1.019
2018.11.14 09:20	User deleted	2.01.0.1.021
2018.11.14 09:20	Deleted Measurement	2.01.0.1.017
2018.11.14 09:20	User deleted	2.01.0.1.021

## Quick Note advantages

- support Good Laboratory Practice
- messages saved in Smart PRO events log
- can be shown on reports in LabDesk software
- internal information in laboratory
- control/supervision of the process





## Quick Change - quick and easy change of parameters

Quick change of the set parameters is only possible in the program started by the same user.

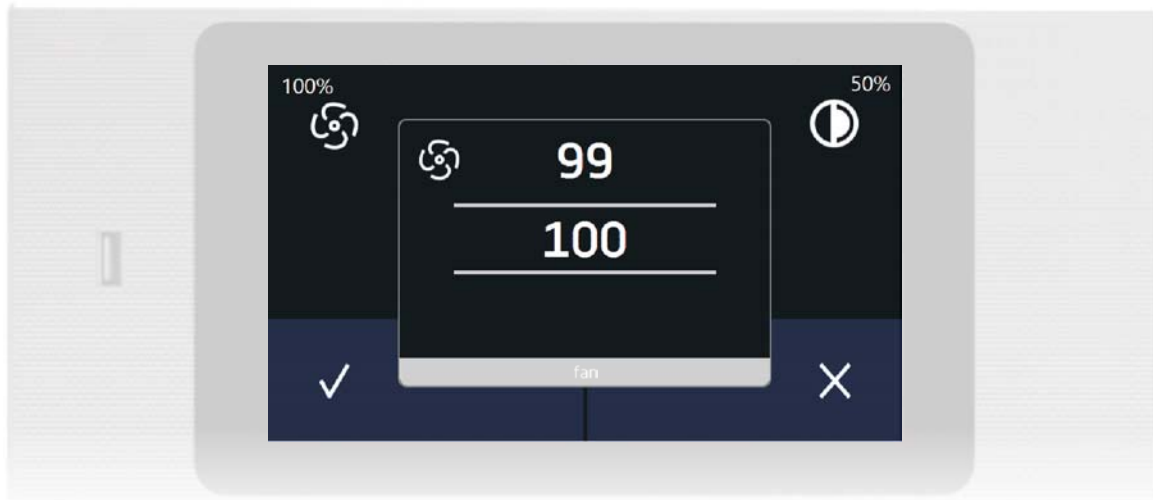

**Temperature** - you can change temperature settings.

The temperature cannot be lower than under temperature protection +2°C and higher than over temperature protection -2°C.



**Fan** - allows to control the fan speed between 0% to 100% (according to chamber type).



**Air flap** - allows you to control the opening of the air flap between 0% to 100% (according to chamber type).



**Time** - you can change program/segment time by scrolling the number of days, hours and minutes. Time can be set from 1 minute to 365 days, 23 hours and 59 minutes.

There is also a possibility to display time in two ways:

- elapsed time of the program/segment
- remaining time of the program/segment.



You can also set continuous operation by pressing the icon of infinity.

## Touch screen unlocking

To avoid accidental program switch off or change of the settings, e.g. when cleaning the screen, a screen lock function has been introduced.

If you touch a locked display a panel with circles will pop up.

You need to swipe a blue circle into the white one in order to unlock the screen.



## Alarm bar and e-mail notifications

When an alarm goes off, you can hear a beeping sound. The display frame and alarm bar flash red.



## Alarm codes

- Door alerts – door ajar alarms
- Critical alerts – critical alarms (eg. sensors malfunction)
- Temperature alerts – under / over temperature alarms
- Humidity alerts – under / over humidity alarms (KK/KKS)

## E-mail notifications

Smart PRO controller was equipped with an E-mail notification function. The user with Super Admin permissions can set and activate e-mail notification reports for up to 3 e-mail addresses.

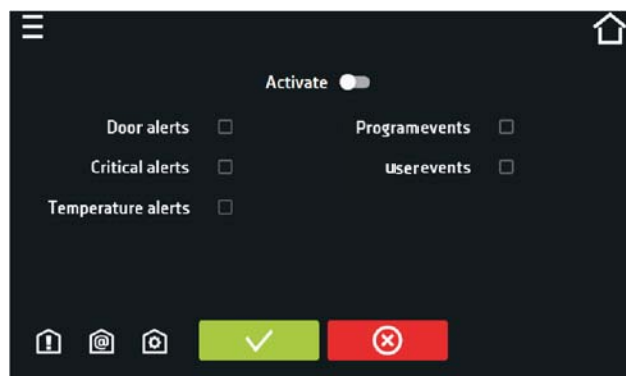

- Door alerts – door ajar alarms
- Critical alerts – critical alarms (eg. sensors malfunction)
- Temperature alerts – under / over temperature alarms
- Program events – information on programs (eg. adding, edition, deletion of a program)
- User events – information on user edition settings (adding, edition, deletion of a user)

## Smart4lab.eu – error codes report

Various types of alarms and warnings may appear during the chamber operation. The Smart and Smart PRO controllers display the type of the alarm / malfunction. You can see the QR error code when click on “details”. Now with your smartphone, you can easily go to our website <https://smart4lab.eu> and check what the code refers to and what you need to do to deal with an unexpected alarm, malfunction or error.

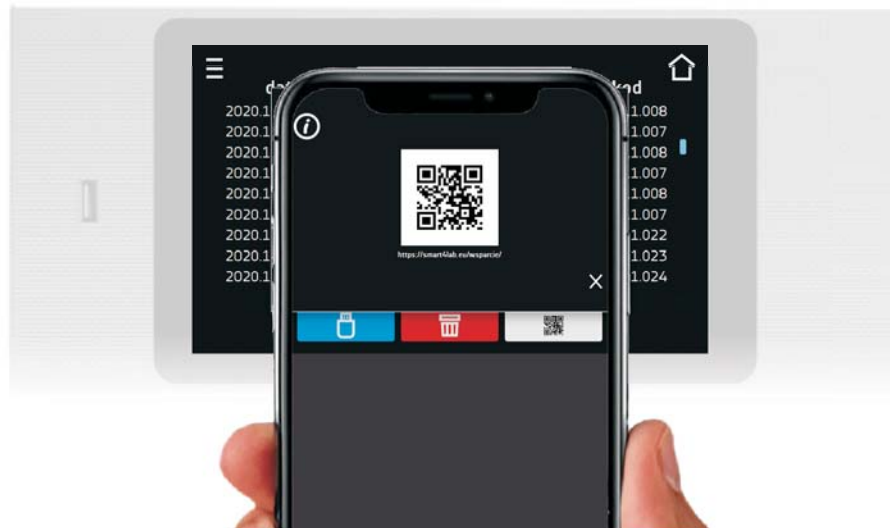

## Smart graph

The Smart PRO controller allows to generate graphs from the records in the data register. For units equipped with two sensors (eg. climatic chambers with temperature and humidity sensor) you are able to see both graphs at the same time. To display one graph only tap twice on the one you wish to see in detail.

To enlarge a fragment of the graph press anywhere on the graph and swipe both right and down at the same time. By swiping left you can return to the normal size of the graph.





## Icon based controller

We created over 150 types of icons to make your work more comfortable and easy. It also makes the Smart & Smart PRO controllers entirely intuitive.

### Information panel icons



Operating icon is only visible when: chamber is heating, cooling or defrosting function is on.



Internal light is switched: ON / OFF



Rotating icon shows that the fan is running when program is active. Icon is stopped when the program is off or when the fan is defect (only ILP).



Closed door, open door. The number above the icon presents open door counter, press the icon to cancel the counter. The counter is also cancelled by turning off the unit.



Activated schedule or start delay. The program will start at the set date/time.



Activated schedule – the program will stop at the set date/time.



Ramp status: Chamber is currently cooling down or heating up to reach set temperature.



Set temperature is reached.

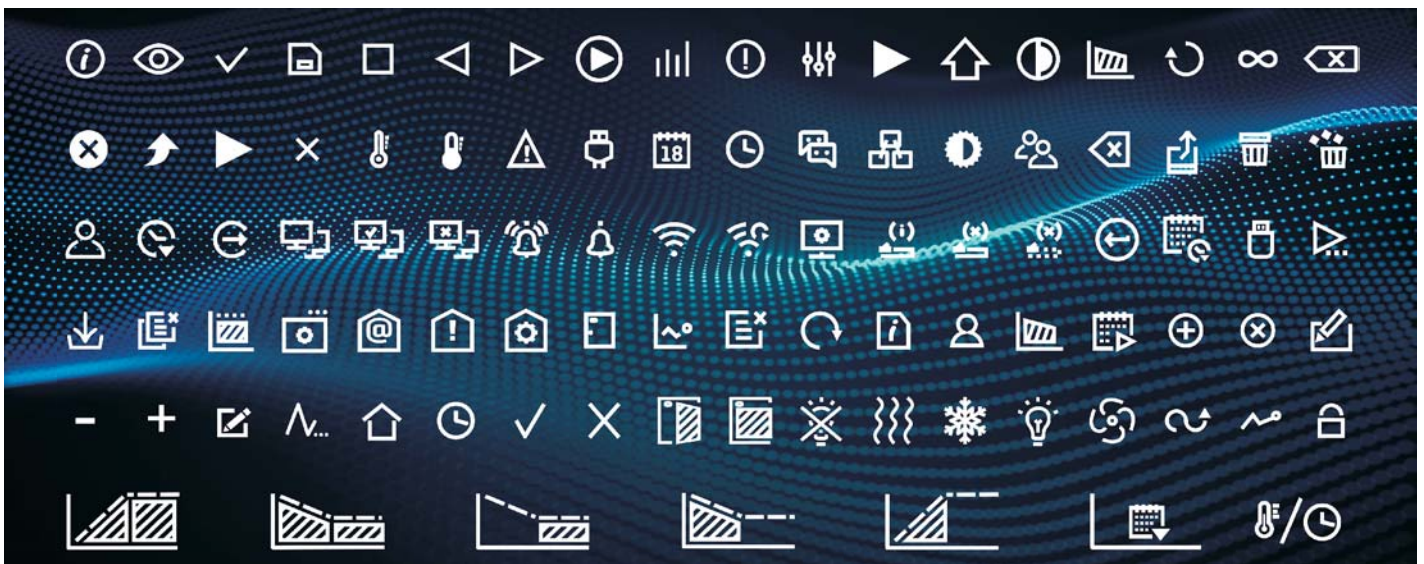

## Smart - Smart PRO simplified version

In the 3rd quarter of 2019 we launched the Smart controller which is a direct successor of the BASIC and STD (standard) controllers, currently found in the ST cooled incubators, CHL laboratory refrigerators, ZL laboratory freezers, ZLN-UT ultra-low freezers, as well as the IL cooled incubators, CL laboratory incubators, SL drying ovens and SR laboratory sterilizers.

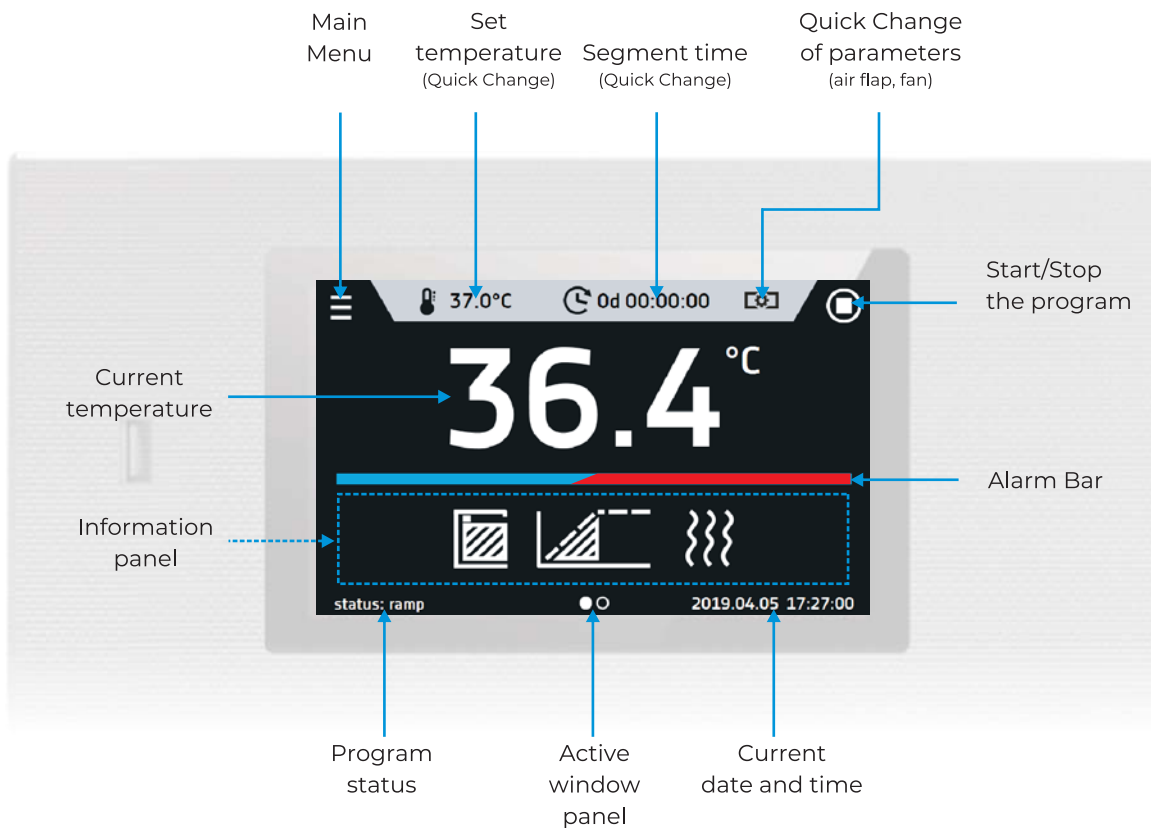

## Advantages of the Smart controller

- 4,3", clear, full colour touch screen
- USB and LAN ports for data download
- multi-segment time and temperature programs
- internal memory for programs and data storage
- operating with gloves on
- event registry
- visual and audible alarm
- instruction manual for direct download
- Quick Change of program parameters: temperature, time, fan, air flap (according to model)
- Alarm Bar - instant visual information about chamber status



Touch screens of the Smart and Smart PRO controllers can be operated with latex gloves!



# COOLING EQUIPMENT



Laboratory refrigerators are equipped with a cooling system and can provide a stable temperature between 0°C ... +15°C



Laboratory refrigerator CHL 2 P Smart PRO



All thermostatic equipment manufactured by POL-EKO can be provided with Calibration Certificate issued by accredited Measurement Laboratory. Detailed information on accreditation is available on website: [www.pol-eko.eu](http://www.pol-eko.eu).

We have been always reaching our goals by designing and implementing innovative technical solutions. Our designers, supported by the R&D unit, combine cutting-edge technology with creativity to deliver state-of-the-art equipment. Customized solutions and out-of-the-box projects that we willingly carry out are a great endeavour and inspire us for further development.



## STANDARD FEATURES

- temperature range 0...+15°C
- quality control protocol (at +4°C)
- English instruction manual
- temperature protection class 1.0 (Smart) and 3.2 (Smart PRO) to DIN 12880
- open door alarm
- castors in standard for models CHL 1200 and 1450
- LAN and USB ports
- internal LED light
- access port (Ø30 mm) on the left wall
- door lock
- wire shelves in B (basic) models, stainless steel wire shelves (INOX) in C (comfort) and P (premium) models
- solid door
- anchoring kit for CHL 500, 700, 1200, 1450 and double/triple chambers

## EXTRA FOR SMART PRO

- Wi-Fi
- LAN cable
- LabDesk

## AVAILABLE VERSIONS

- Smart
- Smart PRO
- TR tropic (on request) for higher ambient temperatures
- double/triple chamber
- combined with ZLN 85 or ST

## SOFTWARE

- LabDesk for data download to a PC via LAN or Wi-Fi (optional for Smart version)

## Application

- storage of water and sewage samples, piezometer leachate
- storage of AAS, GC or HPLC calibration standards
- storage of reagents
- storage of medicines and vaccines



### ■ Dimensions CHL 1

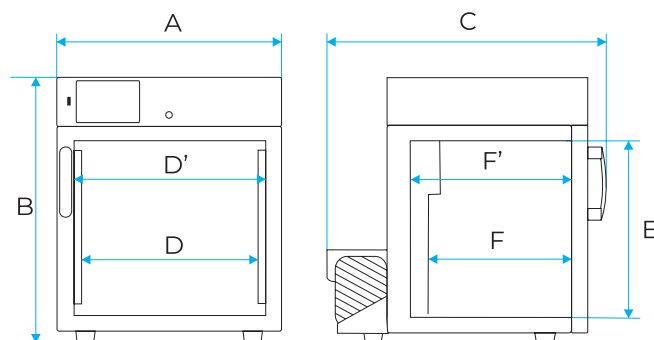

### ■ Dimensions CHL 2/3/4/5/6

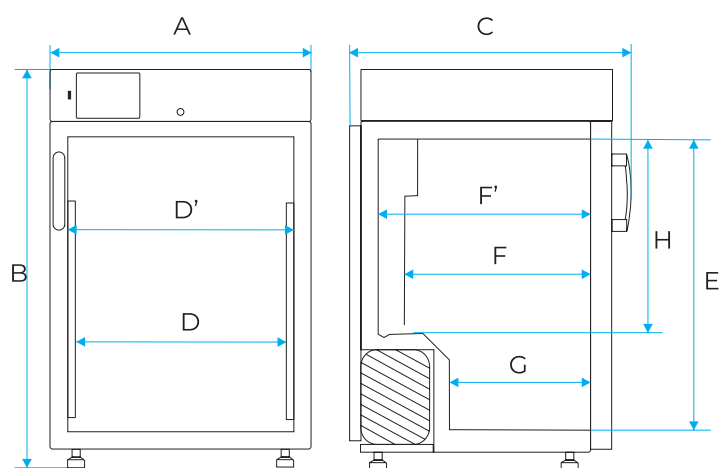

### ■ Dimensions CHL 500/700/1200/1450

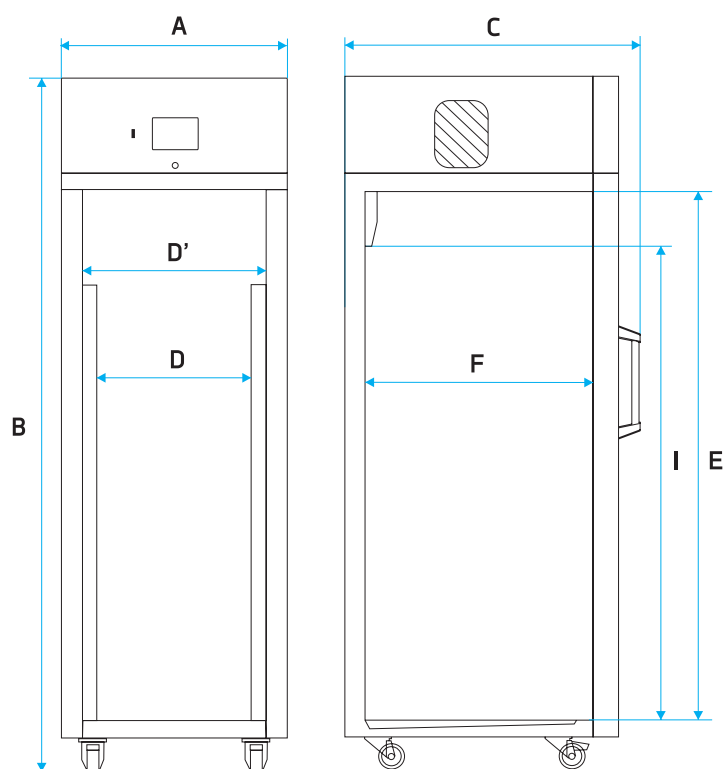



## Laboratory freezers can freeze and store frozen samples

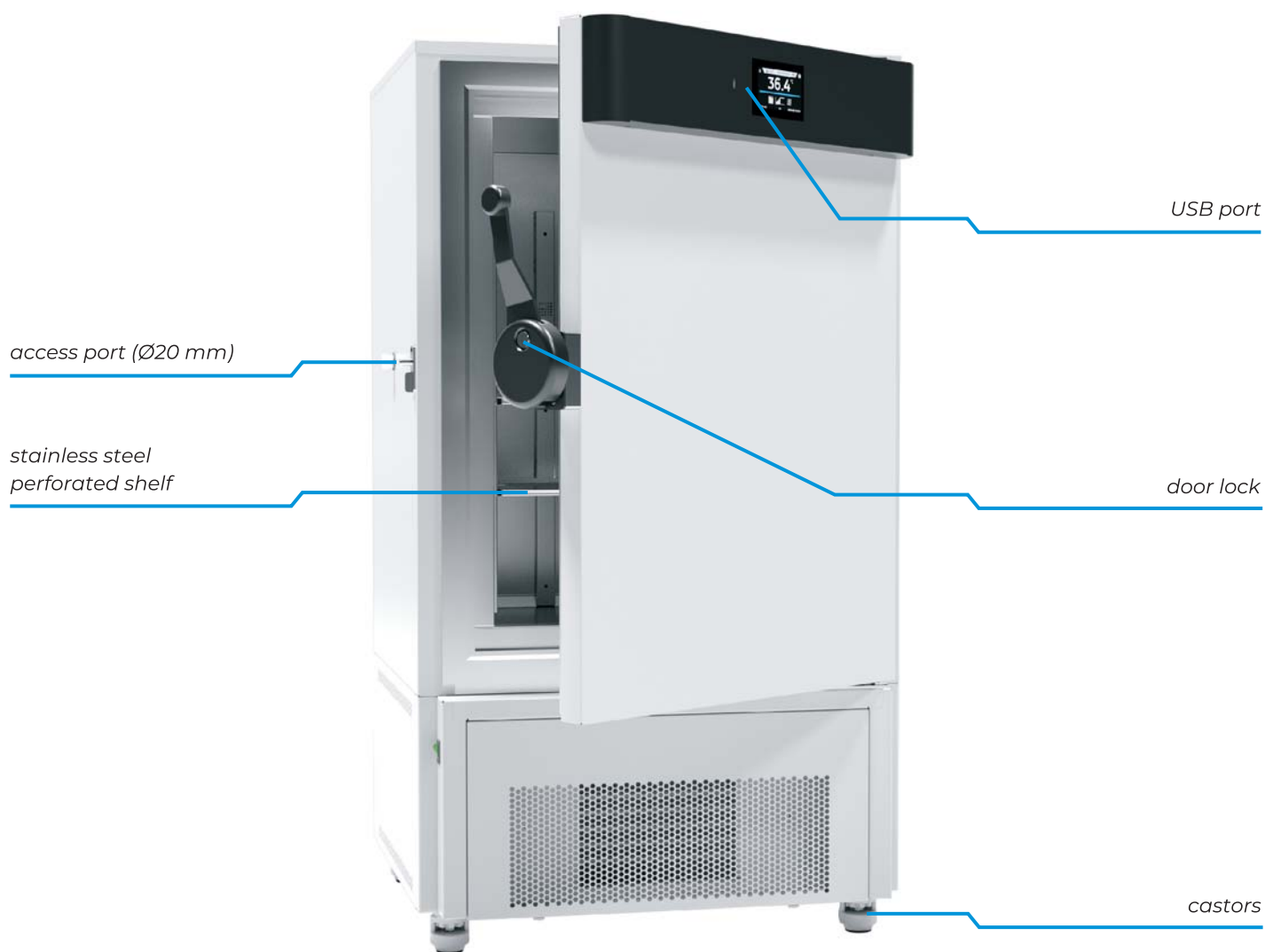

Laboratory freezer ZLN-T 200 C Smart



All thermostatic equipment manufactured by POL-EKO can be provided with Calibration Certificate issued by accredited Measurement Laboratory. Detailed information on accreditation is available on website: [www.pol-eko.eu](http://www.pol-eko.eu).

Advanced control systems and electronics are indispensable for achieving success, there's no doubt about it. Nowadays, no one can imagine working in a laboratory without technology. New solutions emerge in the market every day, so staying up to date with them is a big challenge for our team. We implement the latest hi-tech solutions to provide our customers with great product experience.



## STANDARD FEATURES

- temperature range -25...0°C for ZLN 85 and -40...0°C for ZL-T 125, 200, 300
- quality control protocol (at -20°C)
- English instruction manual
- open door alarm
- castors in standard (except ZLN 85)
- LAN and USB ports
- access port (Ø20 mm) on the left wall
- door lock
- stainless steel wire shelves (INOX) for ZLN 85
- stainless steel shelves with hole for ZLN-T 125, 200, 300 and perforated for ZLW-T 200, 300
- solid door

## EXTRA FOR SMART PRO

- Wi-Fi
- LAN cable
- LabDesk

## AVAILABLE VERSIONS

- Smart
- Smart PRO
- with natural air convection
- with forced air convection
- reinforced

## SOFTWARE

- LabDesk for data download to a PC via LAN or Wi-Fi (optional for Smart version)

## Application

- long-term storage of samples and biological material for research
- storage of easily decomposing material (e.g. solid state)
- freeze resistance tests (e.g. of building materials: concrete, wood etc.)
- pre-freezing
- plasma storage



■ Dimensions ZLN 85

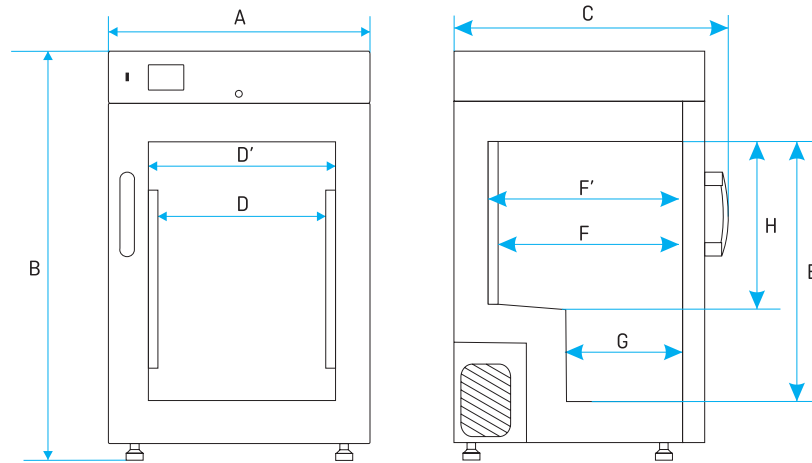

■ Dimensions ZLW-T 200/300

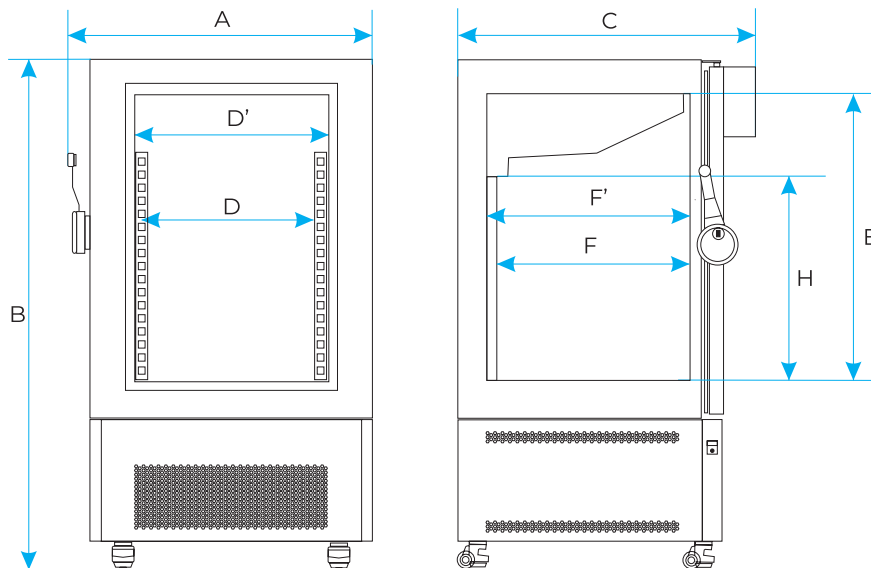

■ Dimensions ZLN-T 125/200/300

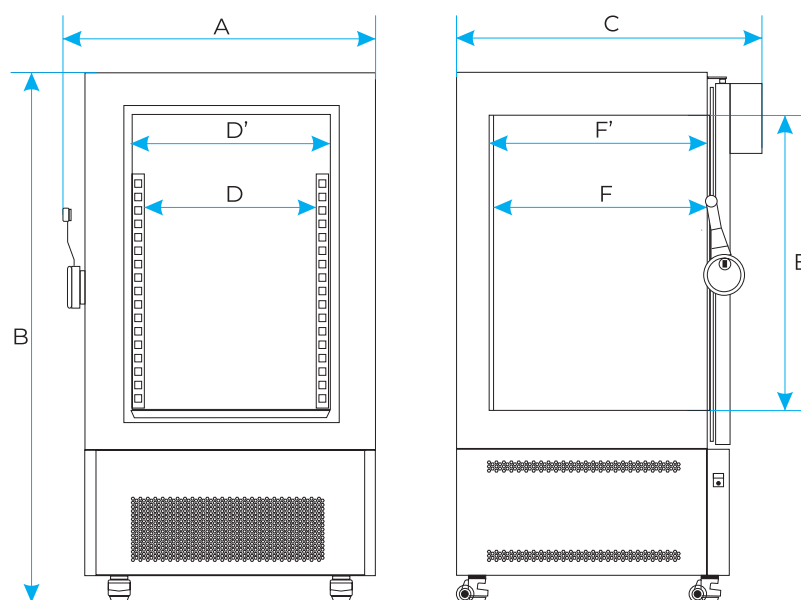

Ultra-low freezers are used for deep freezing of biotechnological samples and other materials which should be stored at very low temperatures



Ultra-low freezer ZLN-UT 300 VIP C Smart



All thermostatic equipment manufactured by POL-EKO can be provided with Calibration Certificate issued by accredited Measurement Laboratory. Detailed information on accreditation is available on website: [www.pol-eko.eu](http://www.pol-eko.eu).

## Options for ultra-low freezers



### ZLN-UT/ST rack with drawers

sturdy and heavy duty, made of stainless steel; feature quick and easy access to all boxes; 3 or 4 drawers (each for 4 boxes) per rack.



### CO<sub>2</sub> back up system

enables the freezer controller to dose CO<sub>2</sub> in case of undesired temperature increase in the chamber. It is supplied with an internal battery. This solution is particularly recommended in the event of a power outage.



### Boxes

made of polypropylene (dimensions 133x133x50mm; each box suits 81 test-tubes of Ø 12,5mm) or made of cardboard.

model	compartments	racks per compartment (option)	boxes per rack (option)	rack set (option)	boxes per compartment (option)	boxes per unit (option)	test-tubes per unit* (option)
ZLN-UT 130	1	8	12	8 x ZLN-UT/ST12	96	96	7 776
ZLN-UT 200	2	8	12	16 x ZLN-UT/ST12	96	192	15 552
ZLN-UT 300	2	8	16	16 x ZLN-UT/ST16	128	256	20 736
ZLN-UT 500	2	4+8	12/16	8 x ZLN-UT/ST12 + 16 x ZLN-UT/ST16	176	352	28 512

\* applies to 12,5 mm diameter test-tubes



### ■ Dimensions ZLN-UT 130 VIP

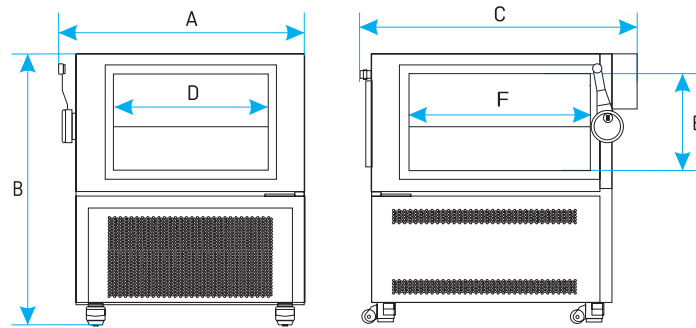

### ■ Dimensions ZLN-UT 200/ 300 VIP

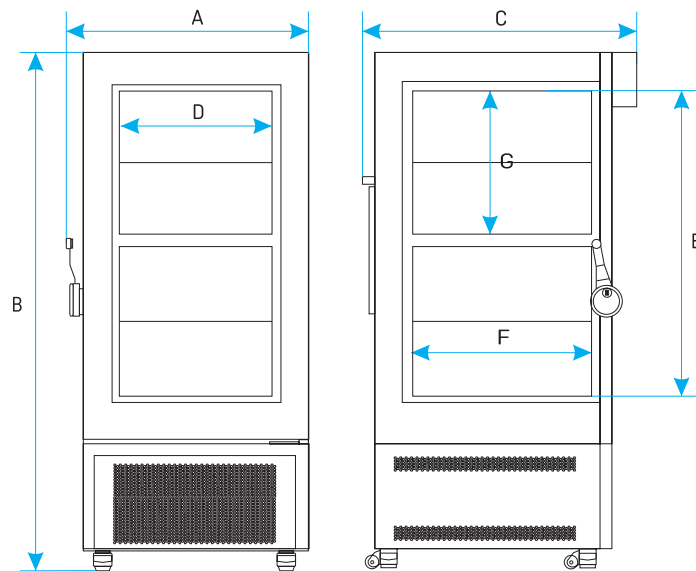

### ■ Dimensions ZLN-UT 500 VIP

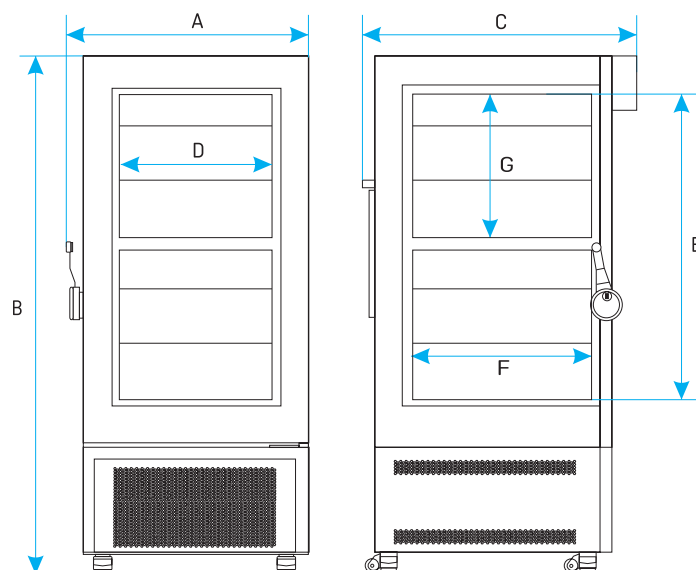



# HEATING AND COOLING EQUIPMENT

Cooled incubators (ST) can provide stable temperature between +3...+70°C regardless of ambient conditions



Cooled incubator ST 2 C Smart PRO



All thermostatic equipment manufactured by POL-EKO can be provided with Calibration Certificate issued by accredited Measurement Laboratory. Detailed information on accreditation is available on website: [www.pol-eko.eu](http://www.pol-eko.eu).

The wide range of our products requires specialisation in many fields. The production of each part involves complex sequence of technological processes, but modern machinery park comes to our aid. To achieve repeatability and highest quality of our components, most of the work is ensured by CNC machines and robots. We put our passion, heart and experience in every detail.



## STANDARD FEATURES

- temperature range +3...+40°C (+70°C for Smart PRO)
- quality control protocol (at +37°C)
- English instruction manual
- temperature protection class 1.0 to DIN 12880 for B (basic) and C (comfort) versions, 2.0 for P (premium) version and 3.3 for Smart PRO
- open door alarm
- castors in standard for models ST 1200 and 1450
- LAN and USB ports
- internal LED light
- access port (Ø30 mm) on the left wall
- door lock
- wire shelves in B (basic) models, stainless steel wire shelves (INOX) in C (comfort) and P (premium) models
- solid door
- anchoring kit for ST 500, 700, 1200, 1450 and double/triple chambers

## EXTRA FOR SMART PRO

- Wi-Fi
- LAN cable
- LabDesk

## AVAILABLE VERSIONS

- Smart
- Smart PRO
- FOT photoperiod (see page 44)
- FIT phytotron (see page 45)
- TR tropic (on request) for higher ambient temperatures
- double/triple chamber
- combined with ZLN 85 or CHL

## SOFTWARE

- LabDesk for data download to a PC via LAN or Wi-Fi (optional for Smart version)

## Application

- BOD determination
- microbiological research
- plant growing and microorganisms breeding at specified temperature
- storage of liquids and samples for physicochemical analysis



Cooled incubators are perfect for incubation of samples in a stable environment, regardless of ambient conditions, at temperatures from -10 up to +100°C



ILW IG Smart PRO cooled incubator



All thermostatic equipment manufactured by POL-EKO can be provided with Calibration Certificate issued by accredited Measurement Laboratory. Detailed information on accreditation is available on website: [www.pol-eko.eu](http://www.pol-eko.eu).



Production of thousands of units a year with an individual approach to every single product while guaranteeing the highest standards requires flexibility and rapidity in action. The continuity of supplies of parts and subassemblies to production stations is ensured by the standards we have developed over the years, which are also monitored by the ERP system.



## STANDARD FEATURES

- temperature range -10°C (option) / 0°C...+70°C (+100°C in Smart PRO)
- English instruction manual
- temperature protection class 2.0 (Smart) and 3.3 (Smart PRO) to DIN 12880
- open door alarm
- castors in standard for models ILW 240, 400, 750
- LAN and USB ports
- access port (Ø30 mm) on the left wall
- door lock
- stainless steel wire shelves (INOX)
- double door (external solid, internal glass)

## EXTRA FOR SMART PRO

- Wi-Fi
- LAN cable
- LabDesk

## AVAILABLE VERSIONS

- Smart
- Smart PRO
- FOT photoperiod (see page 44)
- FIT phytotron (see page 45)
- reinforced

## SOFTWARE

- LabDesk for data download to a PC via LAN or Wi-Fi (optional for Smart version)

## Application

- microbiological tests
- plant growing, microorganisms breeding at precisely controlled environment
- incubation of samples under certain temperature conditions
- incubation of samples for BOD determinations



## ADVANTAGES OF PELTIER-COOLED INCUBATORS



### Environmentally friendly

Elimination of compressor and refrigerants ensures environmental protection.



### Lighter and smaller

The Peltier-element system has reduced the size and weight of the unit.



### Vibration-free

With the introduction of the Peltier-element system, vibrations previously generated by the compressor have been eliminated.



### Perfect performance

The cooling system based on the Peltier-element features excellent temperature stability and uniformity. It also improves the temperaturerecovery time (e.g. after door opening).



### Energy saving

When operating the unit at temperatures close to the ambient temperature, the electricity cost are reduced on average by 40 %

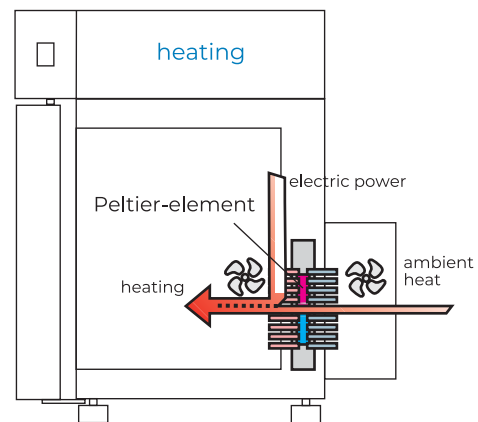
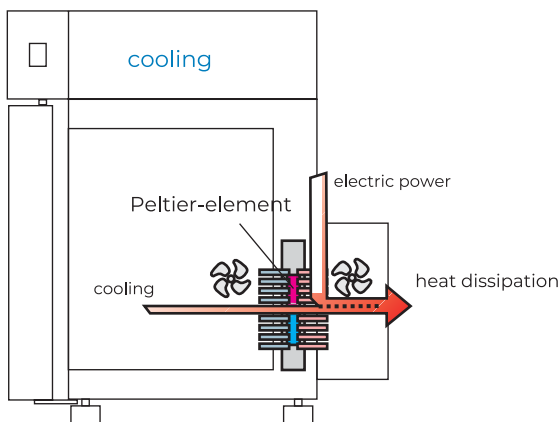

## STANDARD FEATURES

- temperature range 0...+70°C
- English instruction manual
- temperature protection class 2.0 (Smart) and 3.3. (Smart PRO) to DIN 1288
- open door alarm
- castors in standard for ILP 750 model
- LAN and USB ports
- internal LED light
- access port (Ø30 mm) on the left wall
- door lock
- stainless steel wire shelves (INOX)
- double door (external solid, internal glass)

## EXTRA FOR SMART PRO

- Wi-Fi
- LAN cable
- LabDesk

## AVAILABLE VERSIONS

- Smart
- Smart PRO

## SOFTWARE

- LabDesk for data download to a PC via LAN or Wi-Fi (optional for Smart version)

## Equipment with photoperiod

- The photoperiodic (FOT) and phytotron (FIT) systems allow day and night simulation in ST and ILW cooled incubators. The basic difference between the FOT and FIT functions is that in the first case, the light can only be turned on and off in the program, and in the second, you can additionally control its intensity.

The ST and ILW cooled incubators in Smart versions can be equipped with the FOT system.

### FOT option advantages

- day and night simulation software - for each segment it is possible to program temperature, duration time, fan and light efficiency (ON / OFF)
- temperature range for "night": +3°C... +50°C and -10°C... +50°C (for IL with ILW/T option)
- temperature range for "day": +10°C...+50°C
- 840 fluorescent tube lamps installed in side walls in ST cooled incubators; in door or ceiling in ILW cooled incubators
- with FOT option the equipment operates with time priority (see page 83)
- automatic defrosting function in standard

### Photoperiod (FOT option)

	ST FOT2	ST FOT4	ST FOT6	ST FOT8	ST FOT10	ST FOT15	IL FOT2S	IL FOT3S	IL FOT5D	IL FOT6D	IL FOT8D	IL FOT10D
available for models	ST1 ST1/1 ST1/1/1	ST2 ST2/2	ST2 ST3 ST2/2	ST4 ST5	ST500 ST700	ST1200 ST1450	ILW53	ILW115	ILW53	ILW115 ILW240	ILW240 ILW400 ILW750	ILW750
temperature range with photoperiod [°C]	+10 ... +50											
number of lamps in door	-	-	-	-	-	-	-	-	5	6	8	10
number of lamps in ceiling	2	-	-	-	-	-	2	3	-	-	-	-
number of lamps in side walls	-	4	6	8	10	15	-	-	-	-	-	-
adjustable illumination intensity	no											

\*for the ST series with the FOT option, the internal dimensions of the chamber are reduced by 4 cm on each side, the FOT option must be ordered together with the equipment! It is not possible to purchase this option later.

### Application

- microbiological tests
- plant growing, microorganisms breeding at precisely controlled environment
- photostability tests



## Equipment with phytotron

■ The ST and ILW cooled incubators in Smart PRO version (ST 500/700/1200/1450, ILW 115/240/400/750) and climatic chambers can be equipped with the FIT system.

### FIT option advantages

- day and night simulation software - for each segment it is possible to program temperature, duration time, fan efficiency and light intensity (every 10%)
- temperature range for "night": +3°C... +60°C (ST) and -10°C... +60°C (for IL with ILW/T option)
- temperature range for "day": +10°C...+50°C
- lamps installed in over-shelf panels (FIT P), in side walls (FIT S), in door (FIT D) or in door and side walls (FIT DS)
- 840 fluorescent tube lamps (daylight) or LED modules
- with FIT option the equipment can operate with time or parameters (temperature) priority
- automatic defrosting function in standard

### Phytotron (FIT option)

Option*	ST 500/700 FIT DS	ST 500/700 FIT S	ST 500/700 FIT P	ST 1200 FIT P	ST 1450 FIT P	IL 115 FIT P	IL 240 FIT P	IL 400 FIT P	IL 750 FIT P	IL 115 FIT D	IL 240 FIT D	IL 750 FIT D
temperature range with phytotron ON [°C]	+10 ... +50											
number of over-shelf panels with illumination (std/max)	-	-	1/3	1/3	1/3	1/1	1/2	1/2	1/3	-	-	-
lamps in door	yes	-	-	-	-	-	-	-	-	yes	yes	yes
lamps in side walls	yes	yes	-	-	-	-	-	-	-	-	-	-
adjustable illumination intensity	yes											

\* **FIT DS** – illumination in door and side walls; **FIT D** - illumination in door; **FIT S** – illumination in side walls; **FIT P** – illumination in over-shelf panels

ST cooled incubators ST 500, 700, 1200, 1450 with FIT/FOT option are produced with previous cooling system. It is not possible to supply them with monoblock (M) cooling unit.

### Application

- growth of plants and fungus
- seeds germination
- microorganisms and insects breeding
- photostability tests
- food preservation tests
- any kind of research that requires a stable temperature light control (optionally humidity control)
- tests of building materials



## BOD incubators

- The ST BD cooled incubators series for biochemical oxygen demand (BOD) determination, is adapted to work with OxiTop® systems. ST BD series cabinets are equipped with internal power sockets 2, 3 or 4, depending on the model, and it is possible to place inside them respectively 2, 3 or 4 OxiTop® IS 12 sets by WTW.



ST BD 2 Smart



ST BD 4 Smart



ST BD 5 Smart

### ADVANTAGES OF ST BD COOLED INCUBATORS

- Smart controller
- heating and cooling system
- temperature range + 3... + 40°C
- temperature resolution every 0.1°C
- forced air convection
- solid door (optional external glass door)
- access port (Ø30 mm) on the left wall
- internal socket
- open door alarm
- internal LED light
- housing material - powder coated sheet
- chamber material - aluminum
- door lock
- wire shelves with guides
- visual and sound alarm
- temperature sensor damage alarm
- voltage decay control
- real time clock

#### Determination of:

- BOD
- biological decomposition
- oxygen consumption
- complete aerobic biodegradation







# HEATING EQUIPMENT

Laboratory incubators are perfect for incubation of samples at temperatures above ambient up to +100°C



CLN 180 IG Smart PRO laboratory incubator



All thermostatic equipment manufactured by POL-EKO can be provided with Calibration Certificate issued by accredited Measurement Laboratory. Detailed information on accreditation is available on website: [www.pol-eko.eu](http://www.pol-eko.eu).

Hundreds of products in our offer equal hundreds of thousands of elements that the final product consists of. Most of them are produced at our premises in Wodzisław Śląski and this requires continuous availability of materials, raw materials and ready-made components supplied to us. Ensuring the continuity of production and proper quality of parts manufactured for us in many countries in the world is crucial. That is why all these processes must be monitored and verified up to date. To guarantee highest quality of supplied elements every supplier is periodically evaluated.



## STANDARD FEATURES

- temperature range 5°C above ambient temperature...+100°C
- quality control protocol (at +37°C)
- English instruction manual
- temperature protection class 2.0 (Smart) and 3.3 (Smart PRO) to DIN 12880
- open door alarm
- castors in standard for models CL 400, 750, 1000
- Ø40 mm air-flap for CL 15-180 and Ø60 mm for CL 240-1000
- LAN and USB ports
- access port: Ø30 mm for models 53-1000 or Ø9 mm for models 15, 32 on the left wall
- door lock
- stainless steel wire shelves (INOX)
- double door (external solid, internal glass)

## EXTRA FOR SMART PRO

- Wi-Fi
- LAN cable
- LabDesk

## AVAILABLE VERSIONS

- Smart
- Smart PRO
- reinforced

## SOFTWARE

- LabDesk for data download to a PC via LAN or Wi-Fi (optional for Smart version)

## Application

- incubation of samples for microbiological determinations
- analysis of thermal resistance of samples subjected to higher temperatures
- antibodies tests
- bacteria tests
- crystallization observations
- cultivation of thermophilic microorganisms
- pharma stability tests
- food industry denaturalizing tests



**Drying ovens** are designed to provide high temperatures up to 300°C



Drying oven SLW 1000 IG Smart PRO



All thermostatic equipment manufactured by POL-EKO can be provided with Calibration Certificate issued by accredited Measurement Laboratory. Detailed information on accreditation is available on website: [www.pol-eko.eu](http://www.pol-eko.eu).



Such a wide range of products and sale to so many different markets requires extensive knowledge of tax regulations. We are supported in this regard by the ERP integrated management system implemented in 2019 and the involvement of employees of all departments of our company. Data flow and correct system configuration allows precise determination of costs of the tiniest elements and controlling of all processes.



## STANDARD FEATURES

- temperature range 5°C above ambient temperature...+300°C
- quality control protocol (at +105°C)
- English instruction manual
- temperature protection class 2.0 (Smart) and 3.1 (Smart PRO) to DIN 12880
- open door alarm
- castors in standard for models SL 400, 750, 1000
- Ø40 mm air-flap for SL 15-180 and Ø60 mm for SL 240-1000
- LAN and USB ports
- access port: Ø30 mm for models 53-1000 or Ø9 mm for models 15, 32 on the left wall
- door lock
- stainless steel wire shelves (INOX)
- solid door

## EXTRA FOR SMART PRO

- Wi-Fi
- LAN cable
- LabDesk

## AVAILABLE VERSIONS

- Smart
- Smart PRO
- reinforced
- SIMPLE
- with nitrogen blow

## SOFTWARE

- LabDesk for data download to a PC via LAN or Wi-Fi (optional for Smart version)

## Application

- thermal resistance analysis of building materials, electronic and electro-technical components
- tests of properties of products subjected to high temperatures
- drying of wires of papermaking machines
- drying of laboratory glass
- general aging
- preheating
- digestion of proteins
- plant tissues drying
- drug metabolism
- paper drying

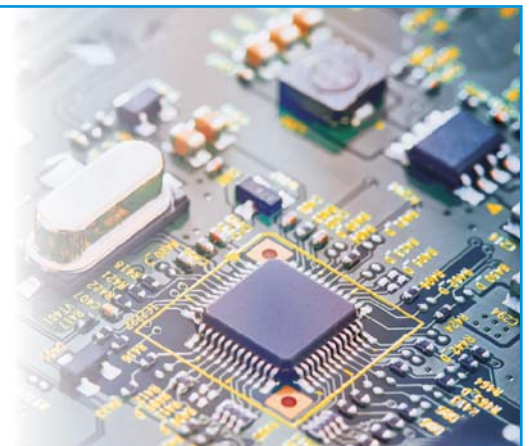

## Drying ovens with nitrogen blow

The PN-ISO 589:2006 norm on the determination of total moisture in hard coal requires that samples of coal subject to oxidation are dried at a temperature of + 105 ° C in a nitrogen flow drying oven.

Detailed requirements and specification of the oven have been described in point 6 of the norm. Use a "nitrogen flow drying oven, allowing to control the temperature in the range from + 105 ° C to + 110 ° C with additional possibility of blowing dry nitrogen stream, at a flow rate of about 15 dryer volumes per hour ”.

To meet these requirements, we have developed a special version of drying ovens that can operate strictly as per the above standard.

### Available models

- SLWN1 - laboratory oven with dry nitrogen blow system of the chamber; the kit includes connections, valves and a laboratory rotameter (which can be calibrated)
- SLWN2 - laboratory oven with dry nitrogen blow system of the chamber; the kit includes connections, valves and a tech rotameter (which cannot be calibrated)

The nitrogen bottle is not supplied.

	SLWN1 15 SLWN2 15	SLWN1 32 SLWN2 32	SLWN1 53 SLWN2 53	SLWN1 115 SLWN2 115	SLWN1 240 SLWN2 240
chamber capacity <sup>1</sup> [l]	15	32	56	112	245

1 - working capacity of chamber can be smaller

For dimensions see page 53 (models SLW 15, 32, 53, 115, 240).



### Calibration

- Calibration in air in 9 points (corners + geometrical center) of the chamber at 1 selected by the customer temperature in accredited laboratory. Calibration is confirmed by 'Calibration certificate'.
- Calibration in nitrogen in 9 points (corners + geometrical center) of the chamber at 1 selected by the customer temperature in accredited laboratory. Calibration is confirmed by 'Calibration certificate'.
- Calibration of laboratory rotameter in accredited laboratory. Calibration is confirmed by 'Calibration certificate'.

## SIMPLE drying oven

Simple in operation laboratory drying oven – convenient unit for customers who do not require advanced programming. The equipment is based on a simple controller that allows you to set the temperature and continuous operation.

**Selling the equipment to all continents of the world is a huge challenge for all the staff responsible for order processing and delivery of products on time. But the knowledge of regulations, customs procedures and experience of our employees gained over the years thanks to cooperating with our distributors guarantees professional service of every single order.**



### STANDARD FEATURES

- temperature range: +5°C above ambient temperature... +250°C
- quality control protocol (at +105°C)
- English instruction manual
- temperature protection 1.0 class to DIN 12880
- access port (Ø30 mm) on the right wall
- stainless steel wire shelves (INOX)
- solid door
- continuous operating

### Application

- tests of thermal resistance of building materials, electronic and electrotechnical parts
- checking the influence of high temperature on the properties of products
- drying laboratory glassware
- pre-heating



Hot-air sterilizers have been equipped with a couple of additional functions that protect samples. They can sterilize at temperatures of up to 250°C



Sterilizer SRW 240 IG Smart



All thermostatic equipment manufactured by POL-EKO can be provided with Calibration Certificate issued by accredited Measurement Laboratory. Detailed information on accreditation is available on website: [www.pol-eko.eu](http://www.pol-eko.eu).

The highest level of customer service is our priority. Our goal is to be a consulting company. We do our best to ensure that our sales department staff are not only simply sales people but also engineers whose knowledge and experience would allow to find the best solution for each application. It is our philosophy. We never leave our customers without support. We approach them with great attention to appreciate their trust in us. Always there to help – we advise, train and make suggestions to our colleagues from the R&D department what needs arise in the market and what solutions the customers expect.



## STANDARD FEATURES

- temperature range: +5°C above ambient temperature... +250°C
- other features like for drying ovens SL (see page 52)

## AVAILABLE VERSIONS

- Smart
- Pass-through sterilizers

## ADVANTAGES OF SR HOT-AIR STERILIZERS

- pre-set sterilization programs (including mask sterilization program)
- automatic door lock during the sterilization program
- automatically closed air-flap after starting the sterilization program
- 5 user programs and 3 pre-set programs

## SOFTWARE

- LabDesk for data download to a PC via LAN or Wi-Fi (optional for Smart version)

### Application

- hot air sterilization
- disinfection of masks, documents, etc.





**Pass-through sterilizers** are made on the basis of standard laboratory sterilizers. They are used on production lines as well for sterilization between clean and dirty areas.



## STANDARD FEATURES

- temperature range: +5°C above ambient temperature... +250°C
- quality control protocol (at +105°C)
- English instruction manual
- temperature protection class 2.0 (Smart), 3.1 (option) to DIN 12880
- open door alarm
- LAN and USB ports
- access port: Ø30 mm on the left wall
- door lock
- stainless steel wire shelves (INOX)
- solid door on both sides
- pre-set sterilization programs
- automatic door lock during the sterilization program
- automatically closed air-flap after starting the sterilization program
- 5 user programs and 3 pre-set programs

## AVAILABLE VERSIONS

- Smart

## SOFTWARE

- LabDesk for data download to a PC via LAN (option)

## Application

- connection between dirty and clean areas
- drying/sterilisation on production lines
- hot-air sterilisation



**Caldera** is a warming chamber for fluids and blankets



CALDERA 250 INOX



All thermostatic equipment manufactured by POL-EKO can be provided with Calibration Certificate issued by accredited Measurement Laboratory. Detailed information on accreditation is available on website: [www.pol-eko.eu](http://www.pol-eko.eu).

We are already present in over 90 countries of the whole world, but still work hard to grow and expand our business. Our goal is to offer the products and solutions to customers from any corner of the globe and make the brand even stronger. To achieve this, we must guarantee professional support and highest level of customer service on site, in the mother tongue. This is the reason why we cooperate closely with local distributors all over the world. They can reach the end users on our behalf and provide them with assistance, advice and care.



## FUNCTIONALITY

- capacities: 70, 150, 200, 250, 300l – dimensions and load examples are specified in the table with technical data
- fast heating-up of the load due to forced air convection
- polished stainless steel housing, stainless steel interior
- bright, energy saving LED internal lighting and tempered glass of the door assure an excellent visibility of the interior
- stainless steel telescopic drawers to prevent the load falling or stainless steel wire shelves in TERM version
- optional stainless steel table

## SAFETY

- safe temperature range: +35°C ... +42°C or +35°C ... +70°C in TERM version, temperature regulation every 1°C
- visual and audible alarm in case set temperature is exceeded for 2°C
- independent temperature protection over 45°C (over temperature protection); 3.1 class according to DIN 12880
- open door alarm (the alarm goes off in case the door is opened for over 1 minute)
- LED display visible from 4 m distance
- door lock – load protection against unauthorized use
- service settings protection against unauthorized use
- internal memory for data storage

**CALDERA was designed according to PN-EN 60601-1-2:2002 EMC – Medical norm for electrical equipment (it does not interrupt the work of the other medical instruments).**



All thermostatic equipment manufactured by POL-EKO can be provided with Calibration Certificate issued by accredited Measurement Laboratory. Detailed information on accreditation is available on website: [www.pol-eko.eu](http://www.pol-eko.eu).



# CO<sub>2</sub> INCUBATORS



The CO<sub>2</sub> incubator offers optimum growth conditions for cell cultures. Very precise temperature control, optimal humidity and CO<sub>2</sub> concentration are undeniable advantages of this product.

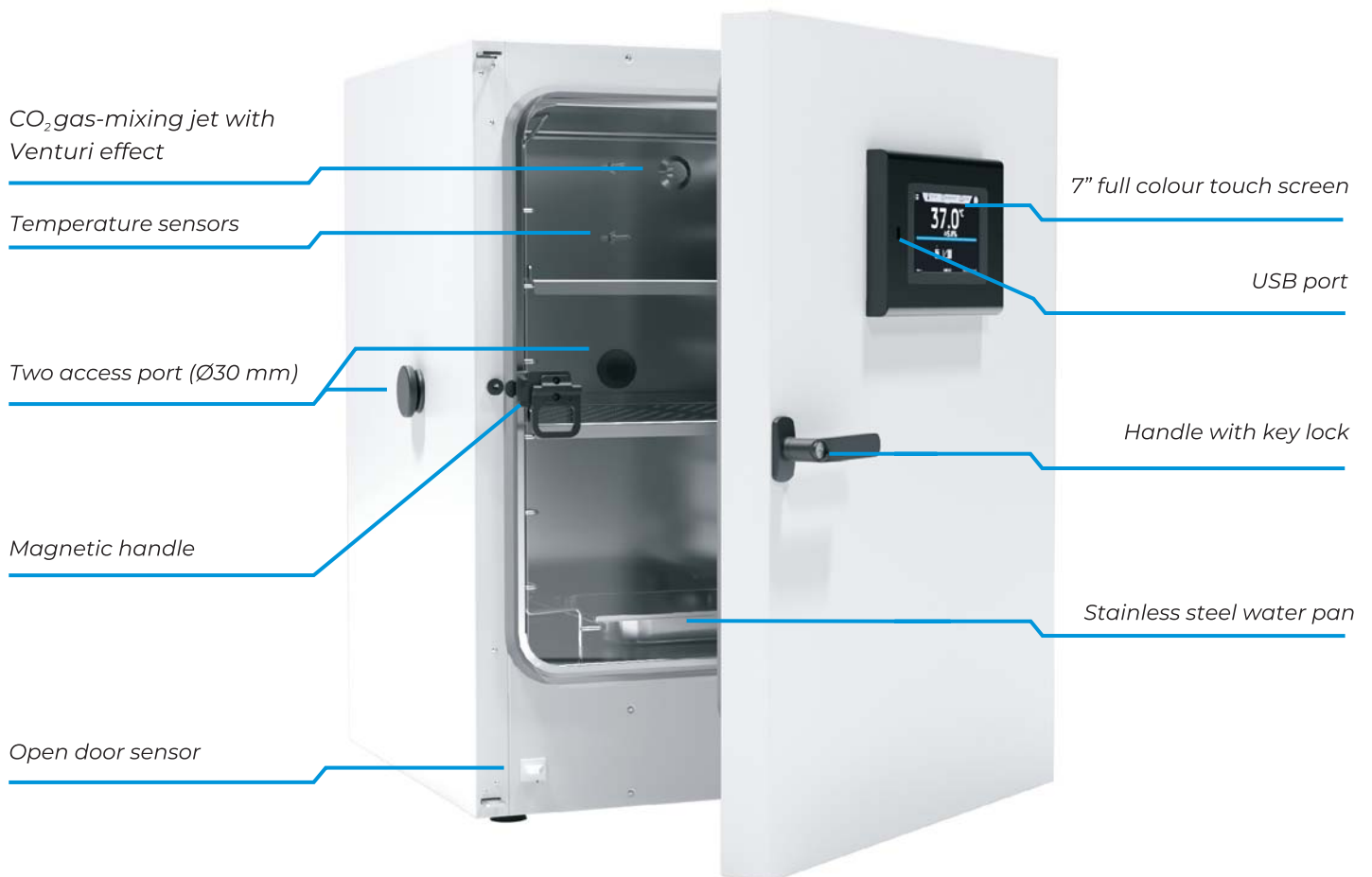

CO<sub>2</sub> Incubator ILC 180 Smart PRO



All thermostatic equipment manufactured by POL-EKO can be provided with Calibration Certificate issued by accredited Measurement Laboratory. Detailed information on accreditation is available on website: [www.pol-eko.eu](http://www.pol-eko.eu).



We are constantly working on development not only of our equipment but also of new products. The CO<sub>2</sub> incubator is our youngest "child" of which we are very proud. We present you a product based on the latest technological solutions, using only top-shelf components. We are convinced that you will appreciate the high quality of our solution.



## STANDARD FEATURES

- Temperature range +5°C...+50°C
- Quality control certificate (at +37°C, 5% CO<sub>2</sub>)
- English instruction manual
- Temperature protection class 3.2 to DIN 12880
- Open door alarm
- LAN and USB ports
- Height adjustable feet
- Two access ports (Ø30 mm) on the left wall and on the rear, both secured with silicone plugs
- Water pan to provide optimal humidity
- Door lock
- Perforated shelves and rack for them to optimal shelf positioning
- Open door sensor
- Silicone gasket
- Magnetic handle for ergonomic internal door opening
- Main power switch incorporated in housing prevents unintentional switch off
- CO<sub>2</sub> gas-mixing jet with Venturi effect to ensure quicker atmosphere mixing and more homogeneous distribution
- Multiple temperature sensors for accurate measurement
- Wi-Fi
- LAN cable
- LabDesk

## CONTAMINATION PROTECTION:

- Hot-air sterilization at 180°C
- Fan-less construction
- Smooth, easy to clean stainless steel interior with rounded corners
- Sterilizable, drift-free Infrared CO<sub>2</sub> sensor
- Inner glass door for sample viewing without changing the conditions in the chamber
- No hidden spaces

## AVAILABLE VERSIONS

- Smart PRO

## SOFTWARE

- LabDesk for data download to a PC via LAN or Wi-Fi

### Application:

- cell cultures
- bacterial cultures
- tissue cultures





# CLIMATIC AND PHYTOTRON CHAMBERS

Climatic chambers with phytotron system can control temperature, humidity and light to create a stable environment



Climatic chamber KK 500 Smart PRO FIT DS



All thermostatic equipment manufactured by POL-EKO can be provided with Calibration Certificate issued by accredited Measurement Laboratory. Detailed information on accreditation is available on website: [www.pol-eko.eu](http://www.pol-eko.eu).

Quality control must be ensured during the whole production process. Final testing process can prove that all the required technical parameters have been met. Highest quality of our products has always been our top priority. Customers are obviously very demanding, as they require state-of-the-art equipment which is so important for their research. It is our passion and devotion to deliver a product we would recommend to ourselves.



## STANDARD FEATURES

- temperature range: 0...+60°C (KK) and 0...+100°C (KKS), +10...+50°C (FIT option with light on)
- quality control protocol (at +25°C, 60%rH)
- English instruction manual
- temperature protection class 3.3 to DIN 12880
- open door alarm
- castors
- LAN and USB ports
- access port (Ø30 mm) on the left wall (at the back in FIT S/DS)
- automatic defrosting function
- deionized water container (for KK)
- door lock
- stainless steel wire shelves (INOX)
- double door (external solid, internal glass)
- Wi-Fi
- LAN cable
- LabDesk software

## AVAILABLE VERSIONS

- Smart PRO
- KK with ultrasonic humidifier
- KKS with steam humidifier
- FIT phytotron

## SOFTWARE

- LabDesk for downloading data to a computer (via LAN or Wi-Fi)

## Application

- growth of plants and fungus
- seeds germination
- microorganisms and insects breeding
- photostability tests
- food preservation tests
- tests of building materials

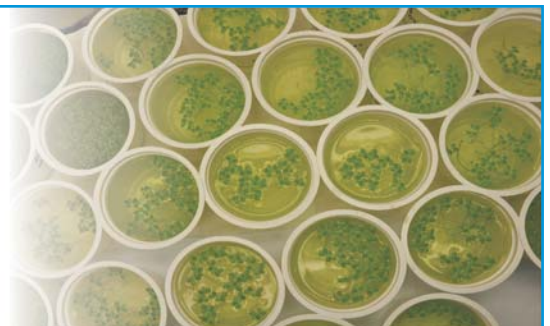



### Climatic chambers with phytotron system (\* /FIT option) except KKS models

- temperature, humidity and light control
- temperature range with light OFF: 0°C ... +60°C
- temperature range with light ON: +10°C ... +50°C
- light colour selection
- max light intensity 15000 lx per FIT P panel (measured 25 cm under the light source)
- day/night simulation with light intensity control
- fluorescent light tubes located in:
  - door and side walls
  - side walls
  - door
  - over-shelf panels
- LED modules located in:
  - over-shelf panels
  - side walls

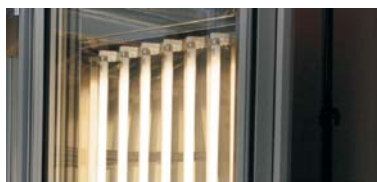

**FIT D** - light tubes installed in door

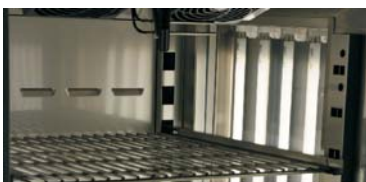

**FIT S** - light tubes installed in side walls



**FIT DS** - light tubes installed in door and side walls

Climatic chambers equipped with phytotron system can control temperature and humidity, as well as light intensity to simulate day and night conditions. Standard light colour is 840 type and the tubes can be installed in the door, side walls or over-shelf panels.

There are also special LED panels designed for plant growing. As most plants use only a part of the sunlight emission, narrow spectrum and specific colours have been used. A and B chlorophyll absorbance maxima are blue and red colour. Chlorophyll absorbs most energy and strongly influences photosynthesis at blue colour spectrum which intensifies growth. Hyper and far red colours stimulate blooming and proliferation.

	KK 115	KK 240	KK 350	KK 400	KK 500	KK 700	KK 750	KK 1200	KK 1450
FIT P	+	+		+	+	+	+	+	+
FIT D	+	+					+		
FIT S			+		+	+			
FIT DS			+		+	+			

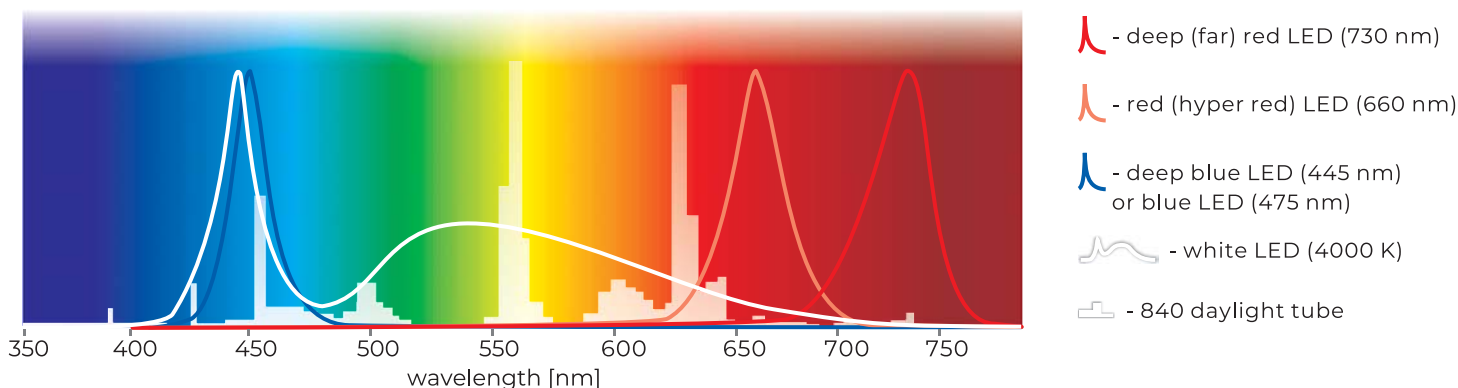

Climatic and phytotron chambers can be adapted to individual customer requirements. A wide range of additional equipment and the possibility of implementing non-standard solutions makes these units satisfy even the most demanding users.





Panel for **FIT P** version



Panel for **FIT P LED** version



Panel for **FIT P LED White** version

Available fluorescent light tubes

- standard type 840 for daylight simulation
- UV tubes for air sterilization and aging tests

Light intensity of a panel:

- FIT P type 840 ~280  $\mu\text{mol}/\text{m}^2\text{s}$
- FIT P LED white 4000 K ~800  $\mu\text{mol}/\text{m}^2\text{s}$  (25 cm distance from a shelf).

Available LED modules

- red (hyper red) – max for wavelength 660 nm
- deep blue – max for wavelength 445 nm
- blue – max for wavelength 475 nm
- deep (far) red – max for wavelength 730 nm
- white – colour temperature 4000 K

The dimmable over-shelf panels can be provided with several independently controlled colours of light. Other configurations on request.

**FIT P version**

Climatic chambers with over-shelf panels with light. Depending on the model, there can be between 1 and 3 panels inside the chamber (standard light colour: 840 daylight). The FIT P version includes 1 over-shelf panel and sockets to allow installation of extra panels if required (to be ordered separately).

The FIT/R3 option allows to control the light intensity separately for each panel.

	KK 115	KK 240	KK 400	KK 500	KK 700	KK 750	KK 1200	KK 1450
standard	1	1	1	1	1	1	1	1
max*	1	2	2	3	3	3	3	3
max light intensity on shelf [lx]	FIT version		5000	10000	15000	15000	15000	15000

\*max number of over-shelf panels with illumination inside the chamber

**FIT P LED version**

The user can choose the light colour and intensity for each program segment. The colour modules can be combined, e.g. far red with blue. Dimming allows to set the required level of intensity. This flexibility provides specific light selection for each plant. The LED modules are long-life – after 25000 operating hours they still feature 90% of the nominal efficiency. The unique optics ensures uniform light distribution for each plant. The LED technology also emits very little heat which helps maintain precise temperature inside the chamber.

The FIT/R3 option allows independent control of each panel and/or each light colour.

## Dry-aging cabinets and chambers

They are a perfect solution for food and meat industry and can be used for ripening of all kinds of meat. The units have been equipped with a touch screen controller to allow precise temperature and humidity control for proper process conditions.

### ■ SD ripening cabinet

A 700-liter cabinet for maturing (ripening) of various types of meat. It has been equipped with a cooling and humidification system and features our brand-new SMART PRO controller. Perfect for commercial and industrial use.

#### Standard accessories

- temperature range from  $-1^{\circ}\text{C}$  to ambient
- humidity control up to 90%
- steam humidifier
- active ventilation function
- fan speed control
- possibility to set up segments and ramps
- internal LED light (spectrum out of UV radiation)
- automatic defrosting
- forced manual defrosting option
- open door counter
- water level sensor
- 20L demineralized water container (option)
- condensate cuvette (option)
- stainless steel tray (option)
- hanger (option)



### ■ KD ripening chamber

They have been designed for ripening, storing and maturing meat. The construction allows uniform air circulation inside the chamber and perfect microclimate to suit ripening. The air inside the chamber comes through stainless steel ventilation ducts. Sterile and odourless steam is ensured by a pressure steam generator. A large and easy to use touch screen improves the user experience. Optional smoke generator provides extra flavour for meat products.

- temperature range  $0 \dots +20^{\circ}\text{C}$
- steam generator
- gravitational ventilation of chamber with manual control
- internal lighting
- automatic defrosting and condensate removal
- 20L demineralized water container
- water level sensor
- smoke generator (option)
- food trolleys with ramp (option)



# LABORATORY EQUIPMENT



## RT 2014 data logger

■ The new generation of RT data loggers enables continuous measurement of temperature and/or humidity values in thermostatic equipment (thermostatic chambers, incubators, refrigerators, freezers, etc...), as well as in the ambient. In case of temperature increase beyond acceptable range (set by the user) or in case of power failures, the RT 2014 logger can send SMS notifications to selected phone numbers.

### The following notifications are available:

- high/low temperature/humidity alarm, alarm notification delay
- 230V power shortage alarm, alarm notification delay
- automatic SMS reports at certain time of the day or on request

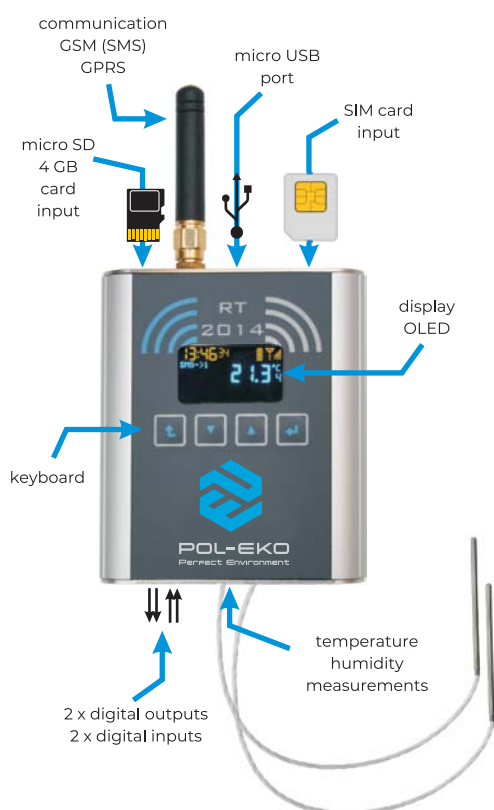

### Data loggers

RT 2014\_1T - temperature or humidity data logger with GSM, single channel model dedicated to temperature or humidity measurements in thermostatic chamber (single channel for one Pt 100 sensor or for one humidity sensor); internal memory (stored data can be downloaded to a PC with LabDesk software); GSM (sends SMS alarms for 5 phone numbers).

RT 2014\_2T - temperature and/or humidity data logger with GSM module, double channel model dedicated to temperature and/or humidity measurements in thermostatic chamber (double channel for two Pt 100 sensors or one Pt 100 and one humidity sensor); internal memory (stored data can be downloaded to a PC with LabDesk software); GSM (sends SMS alarms for 5 phone numbers).

The RT 2014 data logger can be configured in the Avia application installed on your PC .

The recorded data can be accessed by:

- connecting the data logger to a PC
- using the microSD card

The RT 2014 GSM data logger can send text/sound alarms to max 5 mobile phone numbers.

There is a possibility to check the recorder status by dialling the data logger SIM number.

The RT 2014 will text the current parameters back.

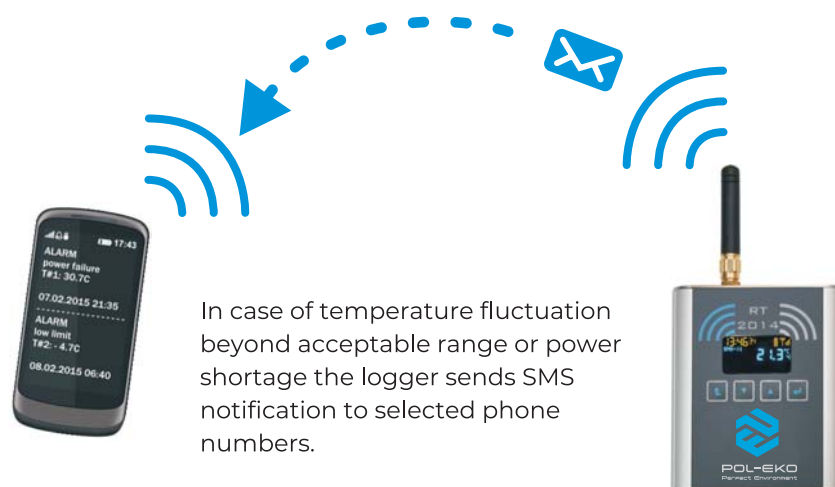

In case of temperature fluctuation beyond acceptable range or power shortage the logger sends SMS notification to selected phone numbers.

### Accessories

Model	Photo	Description	Measuring range	Cable lenght
PT 100 H		temperature sensor for RT 2014 data logger, for high temperatures (recommended for CL/SL)	temp.: 0...+400°C	2,5 m
PT 100 S		standard temperature sensor for RT 2014 data logger (recommended for ST/CHL/IL/KK)	temp.: -40...+180°C	2,5 m
PT 100 L		temperature sensor for RT 2014 data logger, for low temperatures (recommended for ZL, ZLN-UT)	temp.: -110...+120°C	2,5 m
RH_STD		humidity and temperature sensor for RT 2014 data logger (recommended for ST/IL)	rH: 0...80% temp.: 0...+60°C	2,5 m
RH_PREM		humidity and temperature sensor for RT 2014 data logger (recommended for KK)	rH: 0...100% temp.: -50...+100°C	2,5 m
FIT		fitting	-	-
IN	-	binary inputs DIN1, DIN2 – potential-free contacts	DIN1, DIN2	2,0 m
OUT	-	binary outputs DOUT1, DOUT2 – transistor outputs max load 24 VDC 50 mA	DOUT1, DOUT2	2,0 m



## Colony counter

### Advantages

- automatic weight compensation of Petri plates
- anti-shock counting technology
- ringlight technology enables even illumination of the counting field
- bright or dark background selection
- mean value calculation function
- standard marker included
- Petri plates adapters (diameter < 120 mm)
- removable Wolfhügel counting plate
- adjustable push force
- sound and visual counting control
- adjustable position of the magnifying glass
- affordable price

### Standard features

- colony counter
- magnifying glass
- standard marker
- bright and dark background
- Petri plates adapters
- Wolfhügel scale plate

### Accessories

- marker ZM 2002 for external counting



Colony counter is invaluable help in every microbiological laboratory since the most time consuming activity is counting the colonies on Petri plates. An easy-to-use unit featuring quick and precise counting.

LKB 2002



Parameter		
counting field diameter [mm]		120
display		LED (0..999)
magnifying glass		2,5-X
illumination		20 W ringlight
dims [mm]	width	300
	height (without magnifying glass)	90
	depth	325
weight [kg]		4,9
nominal power [W]		22
power supply		230 V 50-60 Hz
warranty		24 months
manufacturer		POL-EKO



### Universal platform

Universal platform for various kinds of vessels with 4 roller clamps (without anti-skid mat).



### Platform for fixing flasks handles

Platform for fixing flasks handles, suitable for flasks of the following capacities: 25ml, 50ml, 100ml, 250ml, 500ml, 2000ml, the handles shall be ordered separately.



### Platform for Petri plates shaking

Platform for shaking Petri plates, bacteria culture flasks and other vessels of low centre of gravity.



### Platform for separatory funnels

Platform for separatory funnels with 3 roller clamps for shaking, salting, extraction and concentration.

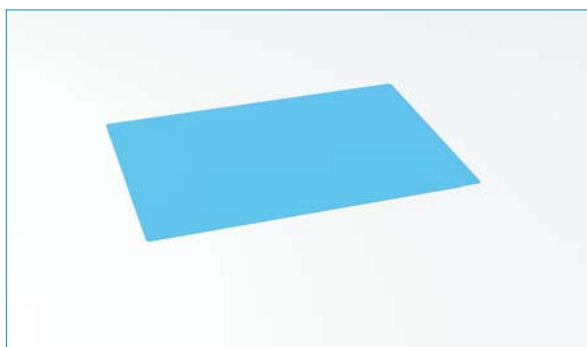

### Anti-skid mat

Anti-skid mat for LS laboratory shakers.



# Compact Line FUME HOODS

**Compact Line fume hoods** ensure safe and comfortable work in the laboratory. Metal construction and a wide range of finishing elements (worktops, internal chamber materials, sinks and fittings, etc.) allow the fume hood to be adapted to the needs of any laboratory. Designed according to PN-EN 14175.

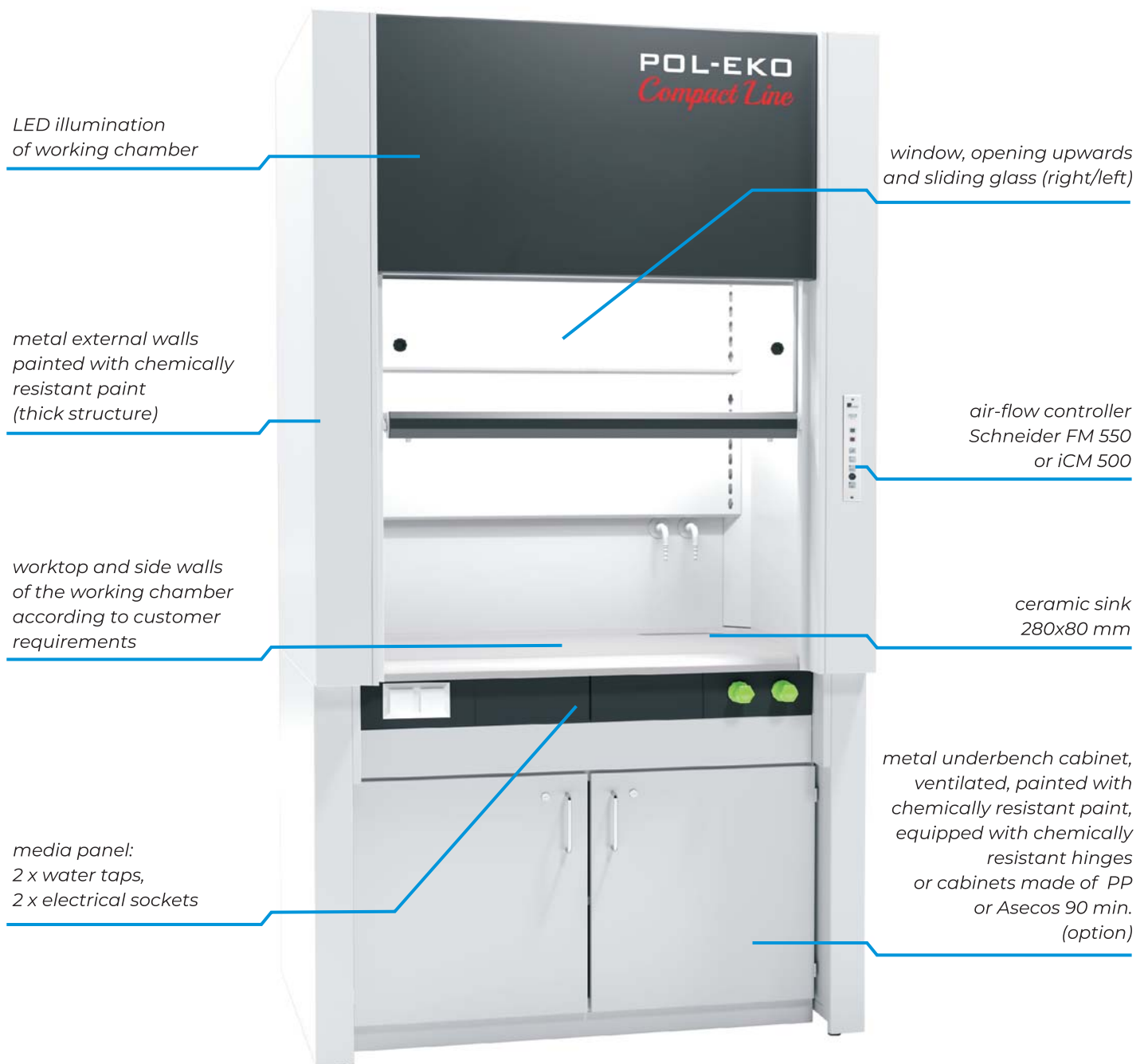

Compact Line DCL-12.00 fume hood

■ Exemplary Compact Line fume hood with additional equipment

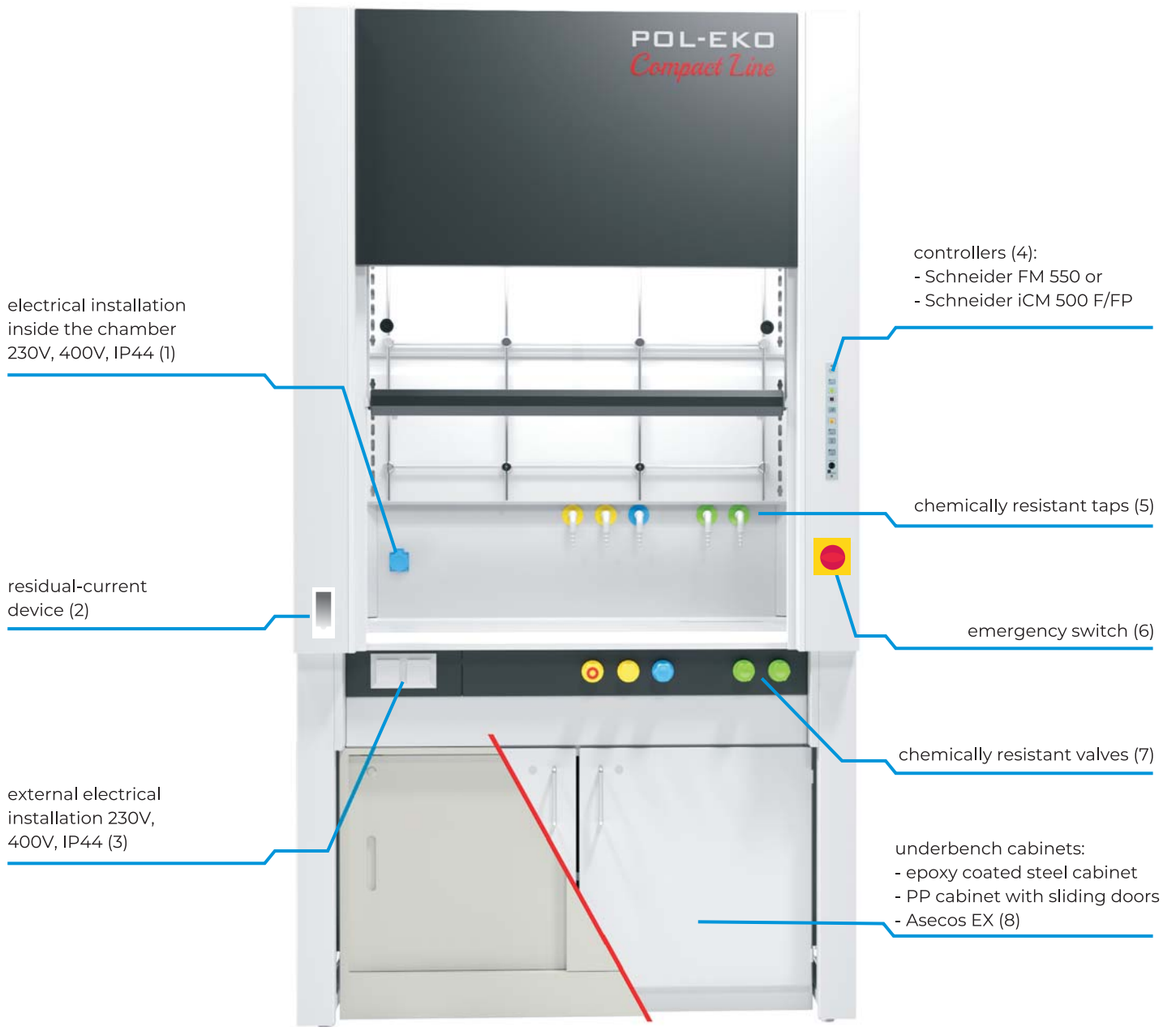





## ADDITIONAL EQUIPMENT

## ■ Non-standard equipment

We have our own engineering and technical facilities thanks to which we are able to design and manufacture non-standard equipment which will meet the requirements of the most unusual applications.

Depending on the individual requirements of customers, the units may have non-standard dimensions and equipment, various temperature ranges as well as an unusual color or type of coating.

Together with our customers, we have already completed many very interesting projects. Some of them are presented below.

### ■ Equipment with non-standard dimensions

- drying oven 2500l
- two-chamber drying oven SLW 500/SLW 500 with the door with viewing window
- pass-through sterilizer 3100l with trolleys
- drying oven 5000l with the possibility of access by a pallet truck
- dry-aging chambers for meat equipped with reinforced shelves and hooks



### ■ Equipment with rotating mechanisms

- laboratory incubator with a built-in slow-rotating grate that allows to mix the content of the bottles
- drying oven with tilting shelf - shelf connected with a lever placed outside, allows you to change the angle of its inclination - a mechanism used to test the flow path of e.g. resins

### ■ Equipment with non-standard illumination

- ST and ILW cooled incubators and incubators with UV-C light
- ST 1-6 cooled incubators with FIT option in side walls
- climatic chambers with phytotron with additional UV light
- ST cooled incubators with illumination in the form of LED strips



## ZA Emergency power supply



The emergency power supply system (ZA) ensures that refrigerators and freezers maintain operating in the event of power outage. It also protects from power supply interferences. The system enables safe operation of your equipment until a stable power supply has been restored or the battery is completely discharged.

In case of storing drugs and vaccines, the battery-powered operation of pharmaceutical refrigerators maintains the "cold chain", even in the event of a power outage of 4 to 30 hours.

### Standard features

- converter with battery charging function
- battery (ies)
- castors
- visual and sound alarm on the operating status
- electric socket type E (230V)
- English instruction manual



ZA emergency power supply can work with all models of CHL laboratory refrigerators, ST cooled incubators, ZL freezers and ILW cooled incubators (ILW 240, 400, 750 models). Battery operation time depends on the size of the unit and selected model.

### Why not the classic "UPS"?

A dedicated battery backup system is necessary for emergency power supply for units equipped with a compressor-based cooling system. At the start of the compressor, the electric current consumption is several times higher than the rated current, which in classic "UPS" used for emergency backup of, for example, computers, triggers safety and automatic shutdown. The emergency power supply produced by POL-EKO can be overloaded by up to 300% for 20 seconds, which allows the compressor to start easily. Additionally, the compressor requires a "clean" sign wave on the power supply. UPSes typically provide voltage with a rectangular or approximate characteristics that can damage the compressor winding.

Parameter	ZA I 6H	ZA I 12 H		ZA I 30H	ZA II 4H	ZA II 8H		ZA II 12H
backup time* [h]	6	12	10	30	4	8	4	12
external dimensions [mm]	A width	660	660	675	660	675		675
	B height	670	670	670	670	670		670
	C depth	375	375	665	375	665		665
weight [kg]	74	105		168	110	173		235
number of batteries [pcs.]	1	1		2	1	2		3
works with the model	CHL/ST 1-6, ZLN85	CHL/ST 1-6	ZLN 85	CHL/ST 1-6	CHL/ST 500-1450 ILW 240-750	CHL/ST 500-1450 ILW 240-750	ZL-T	CHL/ST 500-1450 ILW 240-750
housing material	powder coated sheet							
power / voltage	230V 50-60Hz							
warranty	12 months							
manufacturer	POL-EKO							

\* approximate time of maintaining the operation of the unit with ZA option, depends on the environmental parameters, the chamber load, etc.

## ■ FEKO+ waste water receipt station

FEKO+ is a waste water receipt station intended to work at waste water treatment plants and sewage pumping stations. It can identify the origin of the sewage, as well as each carrier. Moreover, it is able to measure the volume and various parameters of the disposed sewage, such as pH, temperature and conductivity to ensure full monitoring of the waste water.

External control and identification cabinet, made of stainless steel DIN 1.4301, features:

- 7" or 10" colour LCD touch screen
- control system with data archiving
- Windows Embedded based software
- internal memory (city, property address)
- Ethernet communication module (Feko+ Client program) or Wi-Fi (option)
- USB port for data transfer and manual station programming
- MODBUS RTU / TCP or Profibus communication protocol (option)
- RFID key rings 20 pcs.
- carriers identification module
- waste water type identification module
- modular printer with paper cutter
- stainless steel industrial keyboard



## ■ EuroDrop station

The Eurodrop is a waste water receipt station intended for coaches and motorhomes. Standard models are equipped with a flushing function which allows to empty the chemical WC tank, as well as the "grey water" tank. In addition, the Eurodrop stations provide access to drinking water which can be taken to the tank in a coach or camper. What's more, the station has two models of electrical outlets which fit most camper vans.

Standard equipment:

- outdoor LED lighting controlled by astronomical clock
- chemical WC emptying point
- "grey water" emptying point (optional)
- 2 power outlets 1000W and 2000W (optional up to 3680W)
- 2 drinking water nozzles
- 1 non-drinking water nozzle (for flushing chemical WC tank)
- 2 flushing nozzles (for flushing both chemical WC and "grey water" emptying points)

## ■ HYDROMAT water dispenser

HYDROMAT is a station for the automatic dispensing of water, recommended for municipalities with water shortage and lack of water supply system. Water can be taken from a large distributor using the DN80 fire-fighting connector (for large tanks, barrels) or from a small distributor (tap).

Standard equipment:

- backlit and clear LCD display
- control buttons
- RFID proximity card reader
- water meters
- photovoltaic panels (optional)
- coin acceptor (optional)



# 2023

POL-EKO

Manufacturer of laboratory equipment,  
fume hoods and on-line instruments.

POL-EKO sp. k.  
ul. Kokoszycka 172C  
44 - 300 Wodzisław Śląski  
POLAND  
Tel: +48 32 453 91 70

E-mail: [export@pol-eko.com.pl](mailto:export@pol-eko.com.pl)  
[www.pol-eko.com.pl](http://www.pol-eko.com.pl)



like us on  
facebook

[facebook.com/polekoofficial](https://facebook.com/polekoofficial)

Catalogue "Products of POL-EKO" version 15/2023.

While we make every effort to provide accurate technical data, inconsistencies may occur.  
We reserve the right to change technical specifications without notice.

All dimensions are given exact to  $\pm 5\%$ .